



PRODUCT FEATURES

- Compact chilled
- Integral condensor
- Deck forced refrigeration
- Sliding doors front and rear
- Double glazed
- Two adjustable shelves
- Ticket strips on shelves and deck
- Undershelf and canopy LED lights
- Self evaporating
- Solid glass front - optional

Counter top only - no drop into benchtop

CABINET DIMENSIONS & SPECIFICATIONS

Refrigerated 4⁰ factory set point

Model	Cabinet			Shelving no.	Display m2	Total food units	Refrigerant	Operating Current	Connection	Voltage
	Length mm	Depth mm	Height mm							
STGCC9	900	750	950	2 + base		100 x 100 mm	134a	4.5 Amp	10amp 3 pin plug	50/60 Hertz

* prior to installation see, installation guidelines, ventillation requirements and drainage options documents

ELECTRICAL POWER

Electrical power cord 2200mm
3 pin 10 amp 1 phase socket required.
Maximum ambient operating temperature climate class N max 32°C

Maximum shelf load weight 15kg
spread evenly

Rear venting - Cannot be dropped into countertop

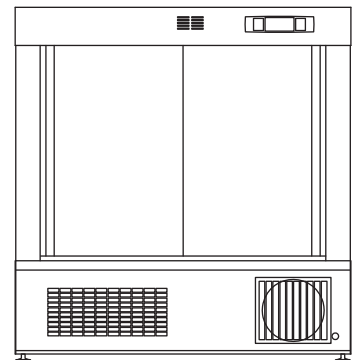
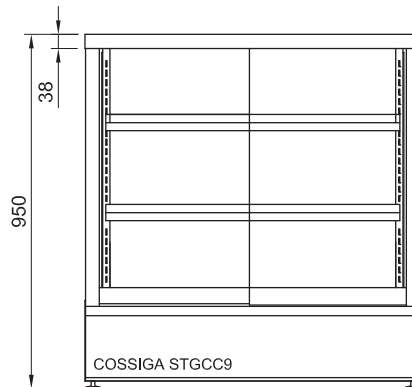
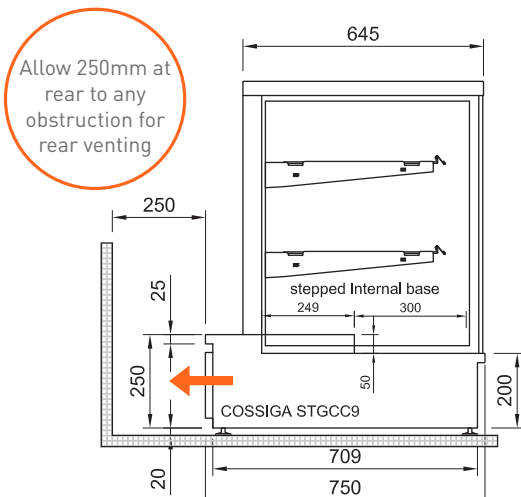
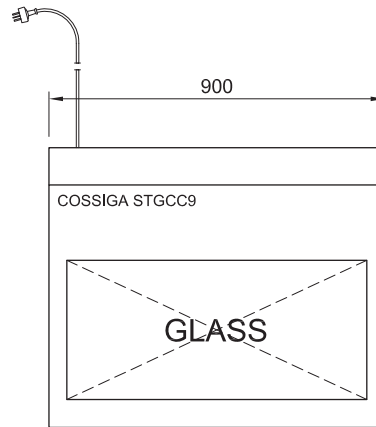

rear view - rear venting



PRODUCT FEATURES

- Compact chilled
- Integral condensor
- Deck forced refrigeration
- Sliding doors front and rear
- Double glazed
- Two adjustable shelves
- Ticket strips on shelves and deck
- Undershelf and canopy LED lights
- Self evaporating
- Solid glass front - optional

Counter top only - no drop into benchtop

CABINET DIMENSIONS & SPECIFICATIONS

Refrigerated 4⁰ factory set point

Model	Cabinet			Shelving no.	Display m ²	Total food units	Refrigerant	Operating Current	Connection	Voltage
	Length mm	Depth mm	Height mm							
STGCC12	1200	750	950	2 + base		100 x 100 mm 121	134a	5.0 Amp	10amp 3 pin plug	50/60 Hertz 240V

* prior to installation see, installation guidelines, ventillation requirements and drainage options documents

ELECTRICAL POWER

Electrical power cord 2200mm
3 pin 10 amp 1 phase socket required.
Maximum ambient operating temperature climate class N max 32°C

Maximum shelf load weight 15kg
spread evenly

Rear venting - Cannot be dropped into countertop

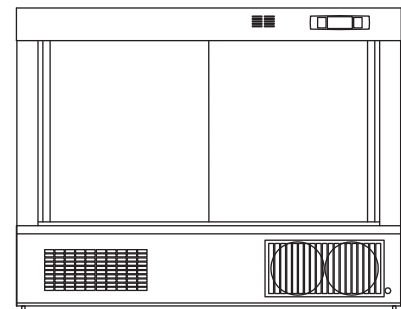
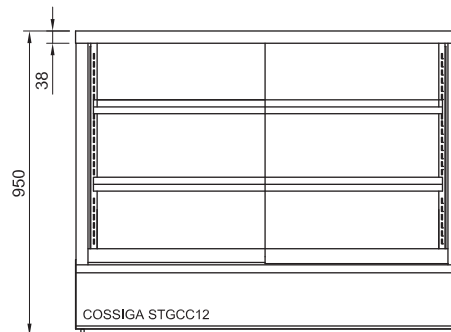
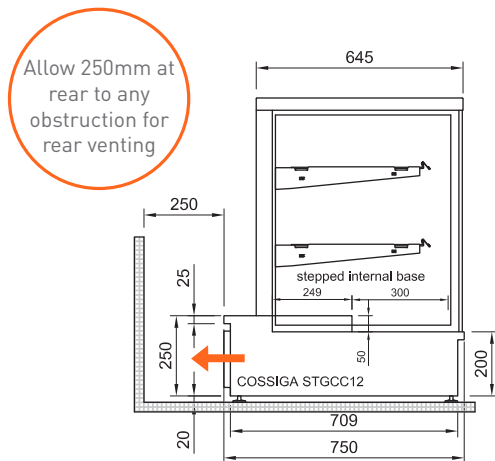
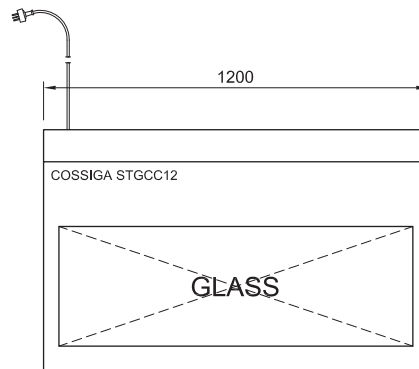

rear view - rear venting