



OE8205/R - Lincat Opus 800 Electric Counter-top Griddle - Ribbed Plate - W 600 mm - 8.0 kW

With a half ribbed plate option for attractive branding presentation marks, the Opus 800 Electric Ribbed Plate Griddle is designed to create appetizing food accurately.

- ✓ Half ribbed plate option for attractive branding presentation marks
- ✓ Precise thermostatic control up to 300°C for consistent results and economical operation
- ✓ Maximised cooking area, griddle plates sit flush to the sides of the unit

Specifications

Summary		Power and Performance	
Brand	Lincat	Total Power kW	8.0
Range	Opus 800	Temperature Range °C	90-300
Power Type	Electric	IP Rating	IP24
Unit Type	Counter-top	Cooking Area (Width x Depth) mm	590 x 600
Available in UK Only	No	Temperature Control	Mechanical
UK Warranty	2 Years Parts and Labour Warranty		
Export Warranty	Contact your local dealer		
GTIN	5056105102526		

Key Specifications		Capacity	
Number of Heat Zones	2	Product Output per Hour	96 x 225g [8oz] steaks [chilled]
Grill Plate Surface Type	Half-ribbed		
Grill Plate Material	Steel		

Weights and Dimensions		Supply Connections	
Unit Height (External) mm	428	Requires Installation	Yes
Unit Width (External) mm	600	Requires Electrical Supply	Yes
Unit Depth (External) mm	800	UK 3 Pin Plug	No
Net Weight Kg	76	Requires Hardwiring	Yes
		Electrical Supply Rating Watts	8,000
		Single Phase Amps	34.8
		Single Phase Voltage	230
		Three Phase Amps	L1=17.4; L2=17.4; L3=N/A
		Three Phase Voltage	400

Shipping	
Packed Weight Kg	83.6
Packed Height cm	63
Packed Width cm	70
Packed Depth cm	85

Available Accessories	
LK11	OPUS 800 LONG LEG KIT
OA8917	Lincat Opus 800 Free-standing Floor Stand with Legs - for units W 600 mm
OA8917/C	Lincat Opus 800 Free-standing Floor Stand with Castors - for units W 600 mm
OA8972	Lincat Opus 800 Free-standing Pedestal with Doors and Legs - for units W 600 mm
OA8972/C	Lincat Opus 800 Free-standing Pedestal with Doors and Castors - for units W 600 mm

Technical Picture

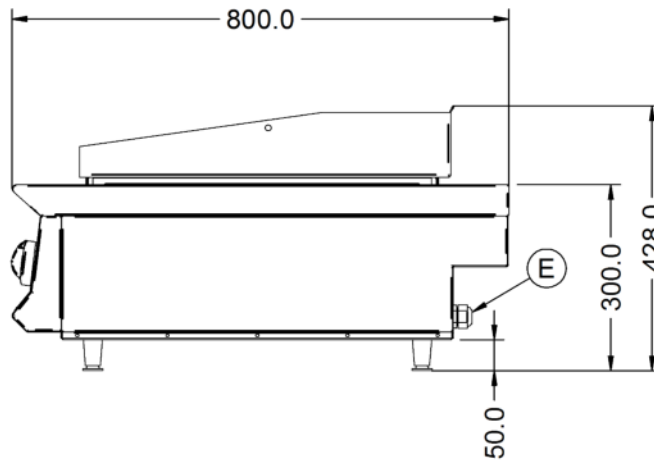
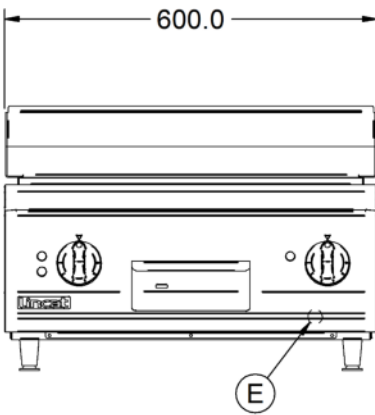
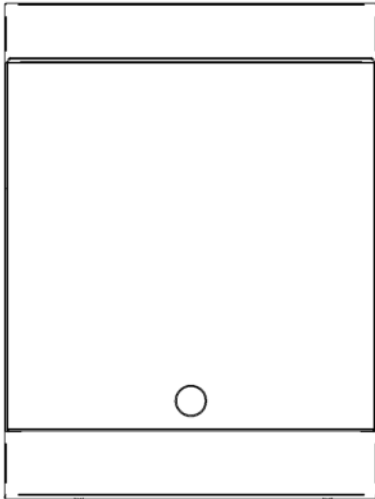

Lincat Limited

Whisby Road,
Lincoln, LN6 3QZ,
United Kingdom

Company No: 2175448

A member company of



Customer Care

Tel: +44 1522 875500
Email: care@lincat.co.uk

Export Customers

Tel: +44 1522 875536
Email: export@lincat.co.uk

Opening Hours

Monday – Friday:
8.30am – 5pm