



PRODUCT FEATURES

- Stainless steel ice deck
- Integral condenser
- 15mm deep well
- Flush mount to bench top
- Drainage

UNIT DIMENSIONS & SPECIFICATIONS

Refrigerated -1° c + 5° c

Model	Cabinet			Bench cut out hole size	Refrigerant	Operating Current	Connection	Weight	Voltage
	Length mm	Depth mm	Height mm						
LSFT3	1008	570	2	982 x 544	134a	2.35 Amp	10amp 3 pin plug	80 Kg.	50/60 Hertz

* prior to installation see, installation guidelines, ventilation requirements and drainage options documents

GLASS AND GANTRY OPTIONS - available separately

COSSIGA free standing gantries (LFSG) available to match units. Refer to LFSG documentation

ELECTRICAL POWER

Electrical power cord 2200mm

3 pin 10 amp 1 phase socket required.

Maximum ambient operating

temperature climate class N max 32° C

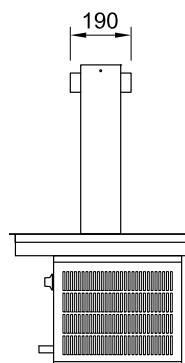
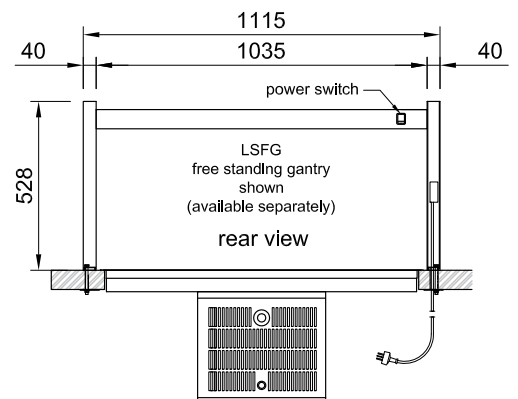
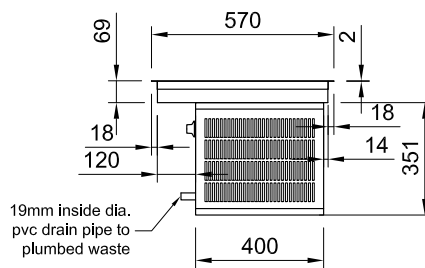
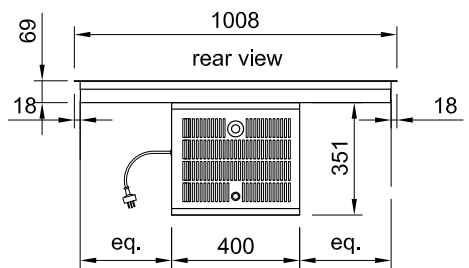
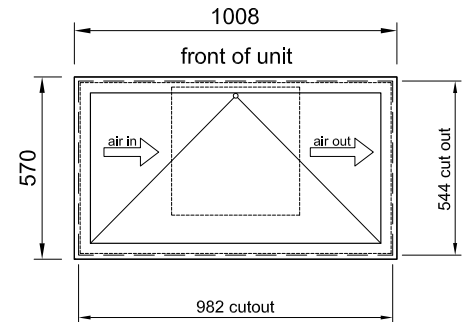

LSFG 15mm EXTENSION KIT Option

Raises gantry height by 15mm

Used to match LSRF, LSCM and LSBM gantry heights when placed together in a bench top.





PRODUCT FEATURES

- Stainless steel ice deck
- Integral condenser
- 15mm deep well
- Flush mount to bench top
- Drainage

UNIT DIMENSIONS & SPECIFICATIONS

Refrigerated -1° c + 5° c

Model	Cabinet			Bench cut out hole size	Refrigerant	Operating Current	Connection	Weight	Voltage
	Length mm	Depth mm	Height mm						
LSFT4	1348	570	2	1322 x 544	134a	2.35 Amp	10amp 3 pin plug	88	240V

* prior to installation see, installation guidelines, ventilation requirements and drainage options documents

GLASS AND GANTRY OPTIONS - available separately

COSSIGA free standing gantries (LFSG) available to match units. Refer to LFSG documentation

ELECTRICAL POWER

Electrical power cord 2200mm

3 pin 10 amp 1 phase socket required.

Maximum ambient operating

temperature climate class N max 32° C

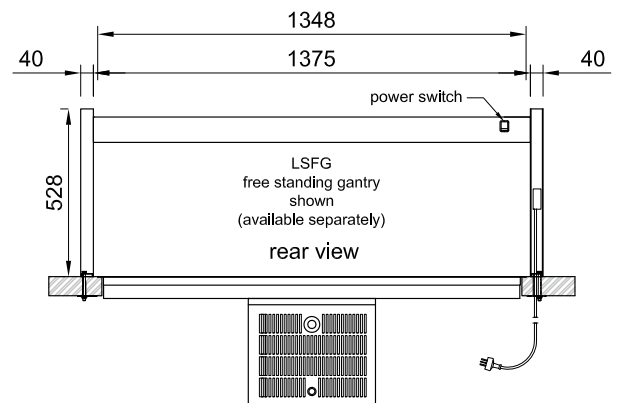
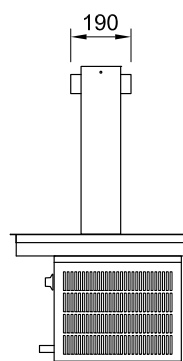
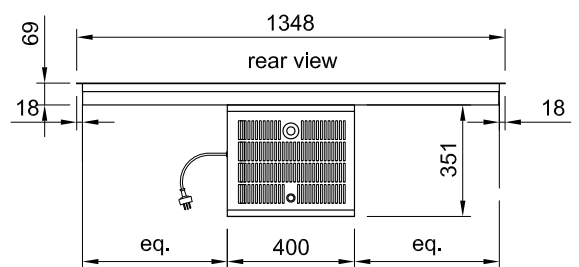
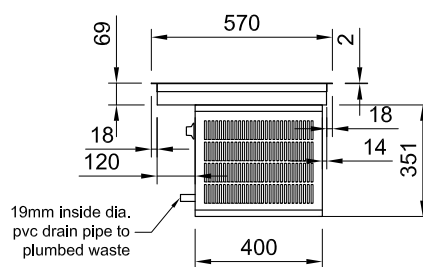
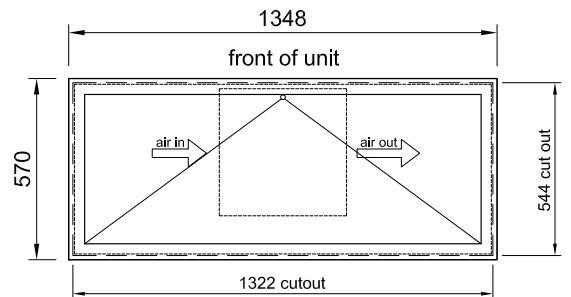

LSFG 15mm EXTENSION KIT Option

Raises gantry height by 15mm

Used to match LSRF, LSCM and LSBM gantry heights when placed together in a bench top.





PRODUCT FEATURES

- Stainless steel ice deck
- Integral condenser
- 15mm deep well
- Flush mount to bench top
- Drainage

UNIT DIMENSIONS & SPECIFICATIONS

Refrigerated -1° c + 5° c

Model	Cabinet			Bench cut out hole size	Refrigerant	Operating Current	Connection	Weight	Voltage
	Length mm	Depth mm	Height mm						
LSFT5	1688	570	2	1662 x 544	134a	2.80 Amp	10amp 3 pin plug	97	240V

* prior to installation see, installation guidelines, ventilation requirements and drainage options documents

GLASS AND GANTRY OPTIONS - available separately

COSSIGA free standing gantries (LFSG) available to match units. Refer to LSFSG documentation

ELECTRICAL POWER

Electrical power cord 2200mm
 3 pin 10 amp 1 phase socket required.
 Maximum ambient operating temperature climate class N max 32° C

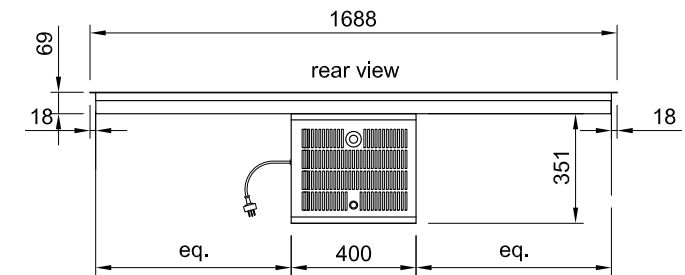
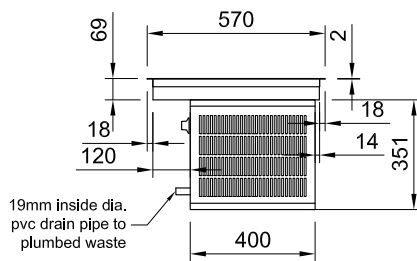
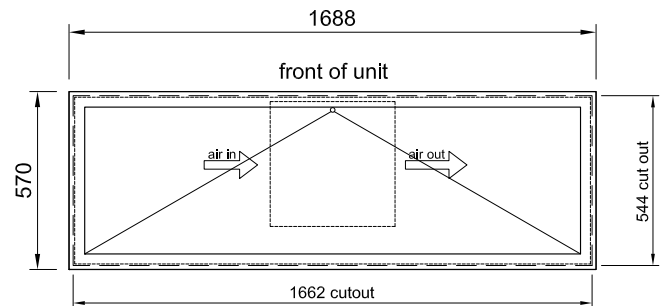

LSFG 15mm EXTENSION KIT Option

Raises gantry height by 15mm
 Used to match LSRF, LSCM and LSBM gantry heights when placed together in a bench top.

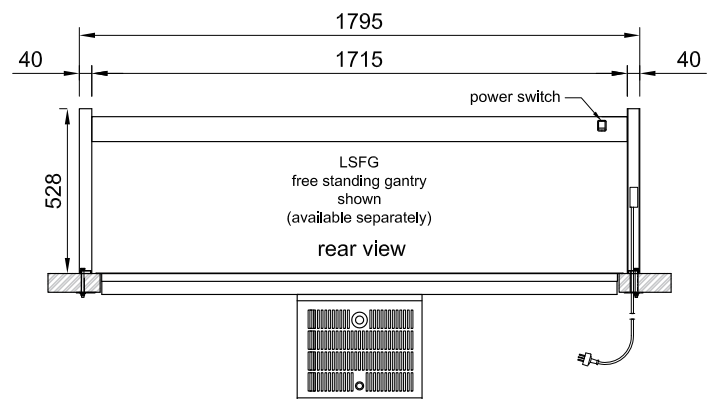
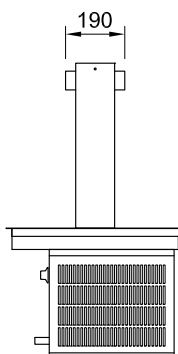



PRODUCT FEATURES

- Stainless steel ice deck
- Integral condenser
- 15mm deep well
- Flush mount to bench top
- Drainage

UNIT DIMENSIONS & SPECIFICATIONS

Refrigerated -1° c + 5° c

Model	Cabinet			Bench cut out hole size	Refrigerant	Operating Current	Connection	Weight	Voltage
	Length mm	Depth mm	Height mm						
LSFT6	2028	570	2	2002 x 544	134a	2.80 Amp	10amp 3 pin plug	106 Kg.	50/60 Hertz

* prior to installation see, installation guidelines, ventilation requirements and drainage options documents

GLASS AND GANTRY OPTIONS - available separately

COSSIGA free standing gantries (LFSG) available to match units. Refer to LFSG documentation

ELECTRICAL POWER

Electrical power cord 2200mm

3 pin 10 amp 1 phase socket required.

Maximum ambient operating

temperature climate class N max 32° C

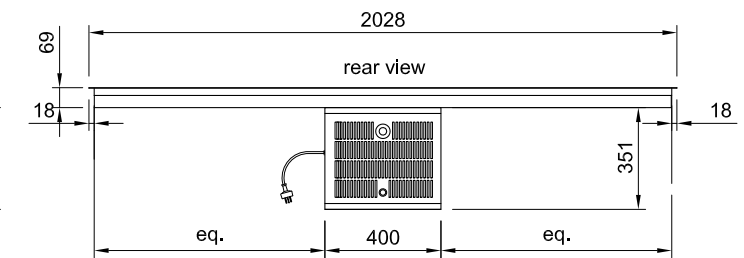
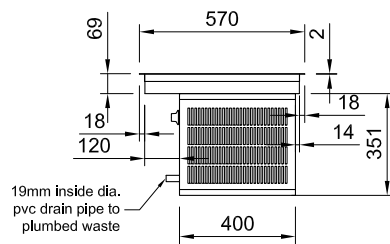
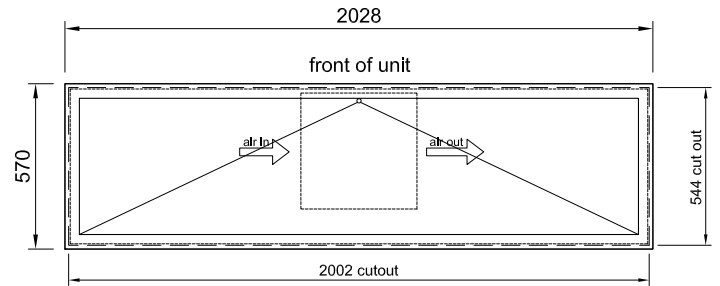

LSFG 15mm EXTENSION KIT Option

Raises gantry height by 15mm

Used to match LSRF, LSCM and LSBM gantry heights when placed together in a bench top.

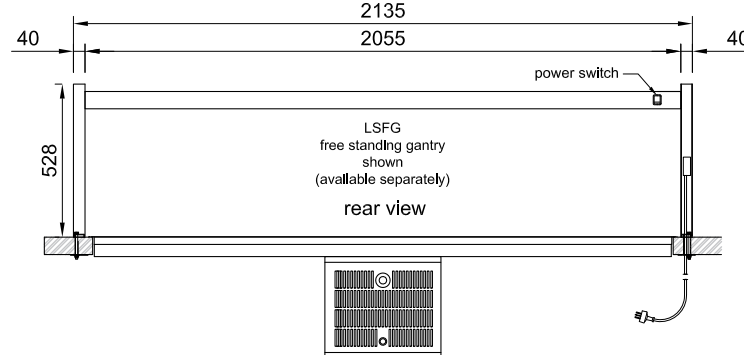
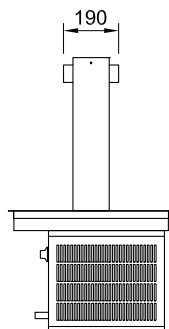



LSFG FREE STANDING ACCESSORY

- Raises gantry height by 15mm
- Used to match LSRF, LSCM and LSBM gantry heights when placed together in a bench top.

LSFG 15mm EXTENSION KIT



ASSEMBLY DIAGRAM

