



## GS7R/N - Lincat Silverlink 600 Natural Gas Counter-top Griddle - Half-Ribbed Plate - W 750 mm - 7.5 kW

Whether you're cooking eggs, bacon, burgers or vegetables, the versatile Silverlink 600 Gas Griddle won't let you down.

- ✓ Flexibility of a half smooth, half ribbed plate to give attractive branding lines to your food whilst being able to cook eggs on the smooth half of the plate. 12 mm thick machined steel plate providing even heat distribution and an easy to clean surface
- ✓ Thermostatically controlled to give accurate temperatures during the cooking process for consistent results
- ✓ Two separately controlled heat zones give you the option of operating either zone independently to provide a smaller cooking area during quiet periods as well as offering versatility when cooking two separate meals simultaneously
- ✓ The plate is fully welded into the frame to prevent leaks and places where food and carbon can build up
- ✓ Front mounted control for easy of use during cooking
- ✓ Piezo ignition for easy lighting of the burners
- ✓ Flame failure device for maximum safety

### Specifications

#### Summary

<b>Brand</b>	Lincat
<b>Range</b>	Silverlink 600
<b>Power Type</b>	Gas
<b>Gas Type</b>	Natural Gas
<b>Unit Type</b>	Counter-top
<b>Available in UK Only</b>	No
<b>UK Warranty</b>	2 Years Parts and Labour Warranty
<b>Export Warranty</b>	Contact your local dealer
<b>GTIN</b>	5056105104971

#### Power and Performance

<b>BTU per Hour</b>	25,590
<b>Total Power kW</b>	7.5
<b>Cooking Area (Width x Depth) mm</b>	712 x 405
<b>Temperature Control</b>	Mechanical

#### Key Specifications

<b>Number of Heat Zones</b>	2
<b>Grill Plate Surface Type</b>	Half-ribbed
<b>Grill Plate Material</b>	Steel

#### Capacity

<b>Product Output per Hour</b>	180 x 115g [4oz] burgers [frozen], 140 x 225g [8oz]
--------------------------------	---

#### Weights and Dimensions

<b>Unit Height (External) mm</b>	415
<b>Unit Width (External) mm</b>	750
<b>Unit Depth (External) mm</b>	650
<b>Net Weight Kg</b>	54

#### Supply Connections

<b>Requires Installation</b>	Yes
<b>Requires Electrical Supply</b>	No
<b>Gas Connection BSP</b>	1/2"
<b>Gas Consumption at full rate Natural m<sup>3</sup> per Hour</b>	0.71
<b>Gas Pressure Natural mbar</b>	16.0
<b>Total heat input at full rate Natural kW</b>	7.5
<b>Total heat input at full rate Natural BTU per hour</b>	23,900

## Shipping

Packed Weight Kg	59.4
Packed Height cm	63.5
Packed Width cm	85.5
Packed Depth cm	70

## Available Accessories

<b>CH01</b>	Caterflex Hose 1/2" - 1 Metre - for use with units up to 66,000 BTU
<b>CH02</b>	Caterflex Hose 1/2" - 1.5 Metre - for use with units up to 56,000 BTU
<b>CN7</b>	Lincat Silverlink 600 Free-standing Ambient Open-Top Pedestal without Doors - W 750 mm
<b>SB7</b>	750 GRIDDLE SPLASHB
<b>SLS7</b>	Lincat Silverlink 600 Free-standing Floor Stand - for units W 750 mm

## Technical Picture

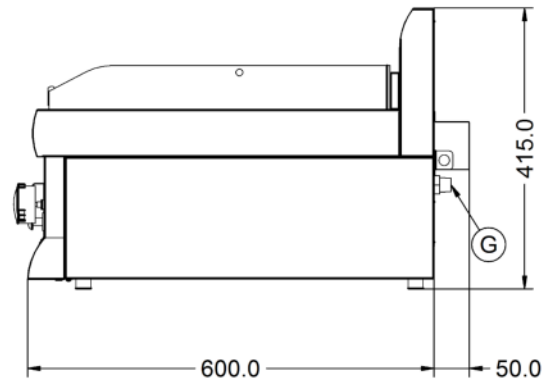
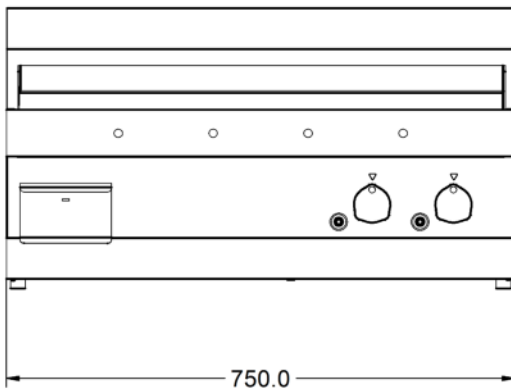
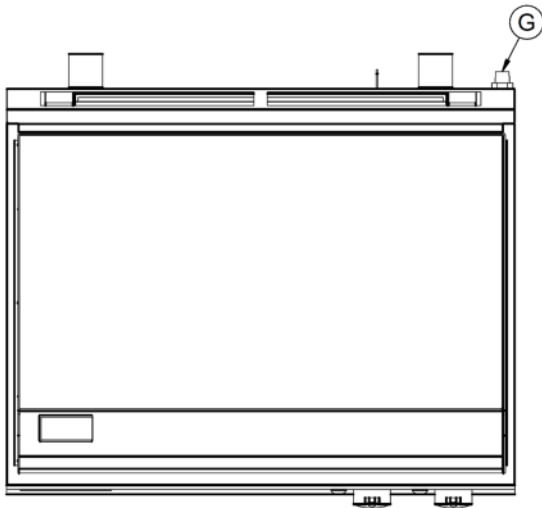



**Lincat Limited**

Whisby Road,  
Lincoln, LN6 3QZ,  
United Kingdom

**Company No:** 2175448

A member company of



**Customer Care**

**Tel:** +44 1522 875500  
**Email:** care@lincat.co.uk

**Export Customers**

**Tel:** +44 1522 875536  
**Email:** export@lincat.co.uk

**Opening Hours**

**Monday – Friday:**  
8.30am – 5pm