

Combi oven

Convotherm maxx pro easyTouch

- 6.10
- 6+1 Shelves GN 1/1
- Gas
- Boiler
- Right-hinged door



Key features

- Natural Smart Climate™ (ACS+) cooking methods: Steam, Combi-steam, Convection
- Natural Smart Climate™ (ACS+) with extra functions:
 - Crisp&Tasty – 5 moisture-removal settings
 - BakePro – 5 levels of traditional baking
 - HumidityPro – 5 humidity settings
 - Controllable fan – 5 speed settings
- easyTouch 10" TFT HiRes glass touch display (capacitive)
- ConvoClean+ fully automatic cleaning system with eco, regular and express modes – with optional single-dose dispensing
- HygieniCare
- WiFi and Ethernet interface (LAN)
- USB port integrated in the control panel
- TriColor indicator ring – indicates the current operating status
- Steam generated by high-performance boiler outside the oven cavity
- LED lighting in the oven cavity
- Appliance door with triple glazing, right-hinged

Standard features

- Cooking methods:
 - Steam (30-130°C) with guaranteed steam saturation
 - Combi-steam (30-250 °C) with automatic moisture control
 - Convection (30-250 °C) with optimized heat transfer
- Operation of easyTouch user interface:
 - 10" TFT HiRes glass touch display (capacitive)
 - Smooth-action, quick-reacting scrolling function
 - Natural Smart Climate™ (ACS+)
- Climate Management
 - Natural Smart Climate™ (ACS+), HumidityPro, Crisp&Tasty
- Quality Management
 - Airflow Management, BakePro, Multi-point core temperature probe, Preheat and cool down function
- Production Management
 - Automatic cooking with Press&Go with up to 399 profiles
 - Integrated cookbook with 7 different categories
 - TrayTimer – load management for different products at the same time (manual mode)
 - TrayView – Load management for automatic cooking of different products using Press&Go
 - Favorites management
 - HACCP data storage
 - USB port
 - ecoCooking – energy-save function
 - LT cooking (low-temperature cooking) / Delta-T cooking
 - Cook&Hold – cook and hold in one process
 - Auto Start
 - Regenerate+ – flexible multi-mode rethermalization function with preselect

Standard features

- Cleaning Management:
 - Convoclean+: Fully automatic cleaning system
 - Quick access to individually created and saved cleaning profiles
 - Cleaning Scheduler
 - FilterCare Interface
- HygieniCare:
 - Hygienic Steam Function
 - Hygienic Handles
 - SteamDisinfect
- Design:
 - Unit door with triple glazing, safety latch, sure-shut function, venting position, right-hinged and LEDs for oven cavity lighting
 - Steam generation by means of a boiler
 - Adjustable appliance feet, from 100 mm to 125 mm
 - Multi-point core temperature probe
 - Integrated recoil hand shower



**Convotherm maxx pro
easyTouch**

- 6.10
- 6+1 Shelves GN 1/1
- Gas
- Boiler
- Right-hinged door

Key features

- Natural Smart Climate™ (ACS+) cooking methods: Steam, Combi-steam, Convection
- Natural Smart Climate™ (ACS+) with extra functions:
 - Crisp&Tasty – 5 moisture-removal settings
 - BakePro – 5 levels of traditional baking
 - HumidityPro – 5 humidity settings
 - Controllable fan – 5 speed settings
- easyTouch 10" TFT HiRes glass touch display (capacitive)
- ConvoClean+ fully automatic cleaning system with eco, regular and express modes – with optional single-dose dispensing
- HygieniCare
- WiFi and Ethernet interface (LAN)
- USB port integrated in the control panel
- TriColor indicator ring – indicates the current operating status
- Steam generated by high-performance boiler outside the oven cavity
- LED lighting in the oven cavity
- Appliance door with triple glazing, right-hinged

Options

- Disappearing door – more space and greater safety at work (see separate datasheet)
- Quality Management: ConvoSmoke – built-in food-smoking function (HotSmoke)
- ConvoGrill with grease management function (on request)
- Steam and vapour removal – built-in condensation module (on request)
- maxx pro BAKE (see separate datasheet)
- Prison version
- Available in various voltages
- Sous-vide probe, external connection
- Core temperature probe, external connection

Accessories

- Production Management: kitchenconnect® (WiFi/LAN), network solution from Welbilt for updating and monitoring appliances from anywhere
- Signal tower – external operating-state indicator
- Banquet system (optionally as a package or individually): Plate rack, mobile shelf rack, transport trolley, thermal cover
- Stands in various sizes and designs
- Racks, choice of GN or BM versions (BM = standard baking sheet size)
- Stacking kits
- Care products for the ConvoClean+ fully automatic cleaning system (multiple and single-measure dispensing)

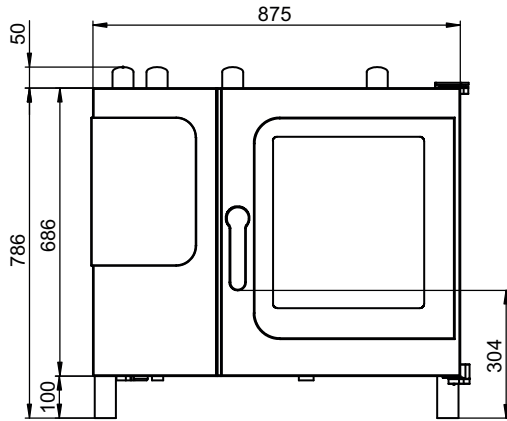
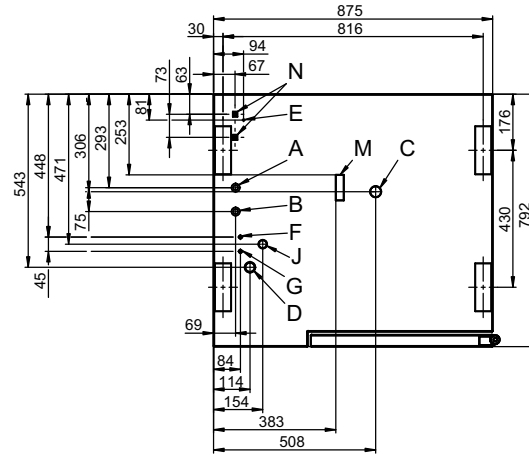
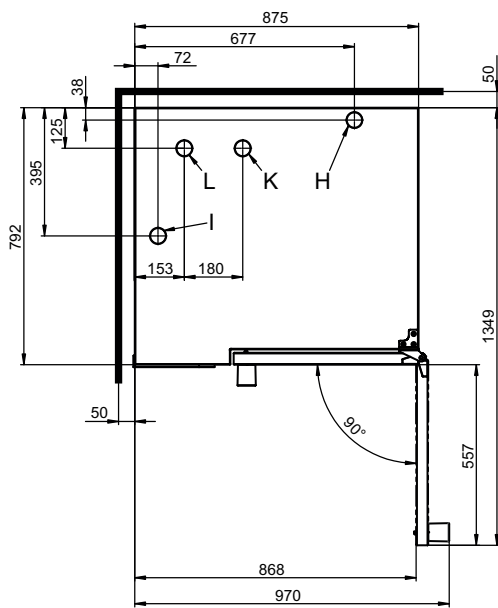
Front view

Connection points

View from above with wall clearances

- A Water connection (for boiler)
- B Water connection (for cleaning, recoil hand shower)
- C Drain connection DN 50
- D Electrical connection
- E Equipotential bonding
- F Rinse-aid connection
- G Cleaning-agent connection
- H Air vent \varnothing 50 mm
- I Dry air intake \varnothing 50 mm
- J Gas supply
- K Convection burner exhaust outlet \varnothing 50 mm
- L Boiler burner exhaust outlet \varnothing 50 mm
- M Safety overflow 80 x 25 mm
- N RJ45 Ethernet port

Dimensions and weights

Dimensions including packaging
 Width x Height x Depth 1100 x 1025 x 940 mm

Weight
 Empty weight without options* / accessories 131 kg
 Weight of packaging 25 kg

Safety clearances**

Rear	50 mm
Right	50 mm
Left (see installation instructions)	50 mm
Top***	1000 mm

Installation instructions

Absolute tilt of unit in operation*	max. 2° (3.5%)
Clearance from heat sources	min. 500 mm
Recommended clearance for service, left side of unit	min. 500 mm

* Adjustable feet included as standard.

The combi oven must be set up with 3 sides free to provide access for cleaning. As an alternative, use a 150 mm high foot; on request.

* Weight of options 15 kg max.

** Required for functionality of appliance.

*** Depends on type of air ventilation system and nature of ceiling.

Loading capacity

Max. number of food containers	
GN 1/1*	6+1
600 x 400** baking tray	5
Plates max. Ø 32 cm, Ring spacing 65 mm**	20
Plates max. Ø 32 cm, Ring spacing 78 mm**	15
Maximum loading weight	
GN 1/1 / 600 x 400	
Per combi oven	30 kg
Per shelf level	15 kg

* Matching rack included as standard.

** Matching rack available as an accessory.

Electrical supply

1N~ 230V 50/60Hz	
Rated power consumption	0.6 kW
Rated current	2.7 A
Fuse rating	16 A
RCD (GFCI), single-phase frequency converter	Type A/B
Recommended conductor cross-section*	3G2.5
1N~ 100V 50/60Hz	
Rated power consumption	0.6 kW
Rated current	6.3 A
Fuse rating	16 A
RCD (GFCI), single-phase frequency converter	Type A/B
Recommended conductor cross-section*	3G2.5

* Recommended conductor cross-section for wires laid uncovered in air up to 5 m in length.

Gas data

Operating materials	Natural gas, LPG
Exhaust gas extraction system	Air conditioning system with safety shutdown
Connection to gas supply	R 3/4"
Supply flow pressure (CE compliant)	
Natural gas 2H (E)	20 (17 - 25) mbar
Natural gas 2L (LL)	20/25 (18 - 30) mbar
Liquefied gas 3B/P	29/37/50 (25 - 57.5) mbar
Propane 3P	29/37/50 (25 - 57.5) mbar
Heat output	
Natural gas 2H (E)	
Convection burner	11 kW
Boiler burner	11 kW
Natural gas 2L (LL)	
Convection burner	10.5 kW
Boiler burner	10.5 kW
Propane 3P*	
Convection burner	11.5 kW
Boiler burner	11.5 kW
Gas consumption	
Natural gas 2H (E)	1.2 m³/h
Natural gas 2L (LL)	1.4 m³/h
Propane 3P / liquefied gas 3B/P	0.9 kg/h
Exhaust gas output rate	
Natural gas, LPG	max. 51 m³/h

*The heat output is up to 15% higher with 3B/P LPG.

Water connection

Water supply	
Water supply	2 x G 3/4" fixed connection, optionally including connecting pipe (min. DN13 / 1/2")
Flow pressure	150 - 600 kPa (1.5 - 6 bar)
Appliance drain	
Drain version	Funnel drain with P-trap (recommended) or fixed connection
Type	DN 50 (min. internal Ø: 46 mm)
Slope for drain pipe	min. 3.5% (2°)

Water quality

Water-supply connection A* for boiler,
Water-supply connection B* for cleaning, recoil hand shower

General requirements	Drinking water, typically hard water
General hardness**	4 - 20 °dh / 70 - 360 ppm / 7 - 35 °TH / 5 - 25 °e
pH value	6.5 - 8.5
Cl ⁻ (chloride)	max. 60 mg/l
Cl ₂ (free chlorine)	max. 0.2 mg/l
SO ₄ ²⁻ (sulphate)	max. 150 mg/l
Fe (iron)	max. 0.1 mg/l
SiO ₂ (silicate)	max. 13 mg/l
NH ₂ Cl (monochloramine)	max. 0.2 mg/l
Temperature	max. 40 °C
Electrical conductivity	min. 20 µS/cm

* See diagram of connection points, page 2.

** Despite compliance with the general hardness limits, non-hardness deposits may occur in certain cases. Measures must be coordinated with the technical service.

Water consumption

Water-supply connections A, B	
Ø Consumption for cooking**	3.0 l/h
Max. water flow rate	15 l/min

** Including water used for cooling the wastewater.

PLEASE NOTE: See diagram of connection points, page 2.

Emissions

Dissipated heat*	
Latent heat	2100 kJ/h / 0.58 kW
Sensible heat	3500 kJ/h / 0.97 kW
Waste water temperature	max. 80 °C
Noise during operation	max. 70 dBA

* The dissipated heat values were measured as per DIN 18873-1 "Methods for measuring the energy use of equipment for commercial kitchens — Part 1". The type and frequency of appliance usage are decisive for the specification of an air conditioning and ventilation system. These values can be higher than the values indicated for dissipated heat. Guide values can be found in the technical literature, e.g. in VDI 2052. Please consult your specialized design engineer for planning an air conditioning and ventilation system.

ACCESSORIES

(Please refer to the Accessories brochure for detailed information)

Stacking kit

Permitted combinations	6.10 on 6.10 6.10 on 10.10
For a combination of two gas appliances	
Select "Stacking kit for Convotherm 4 gas appliances"	
For a combination of one electric appliance and one gas appliance in the stacking kit	
Select "Stacking kit for Convotherm 4 electric appliances" if:	
Bottom combi oven	EB/ES
Top combi oven	GB/GS
Select "Stacking kit for Convotherm 4 gas appliances" if:	
Bottom combi oven	GB/GS
Top combi oven	EB/ES

Please observe the following points:

- This document is to be used solely for planning purposes.
- Please refer to the Installation manual for further technical data and guidance on installation and positioning.