

High Productivity Cooking Electric Tilting Boiling Pan, 300lt Hygienic Profile, Freestanding

ITEM # _____

MODEL # _____

NAME # _____

SIS # _____

AIA # _____

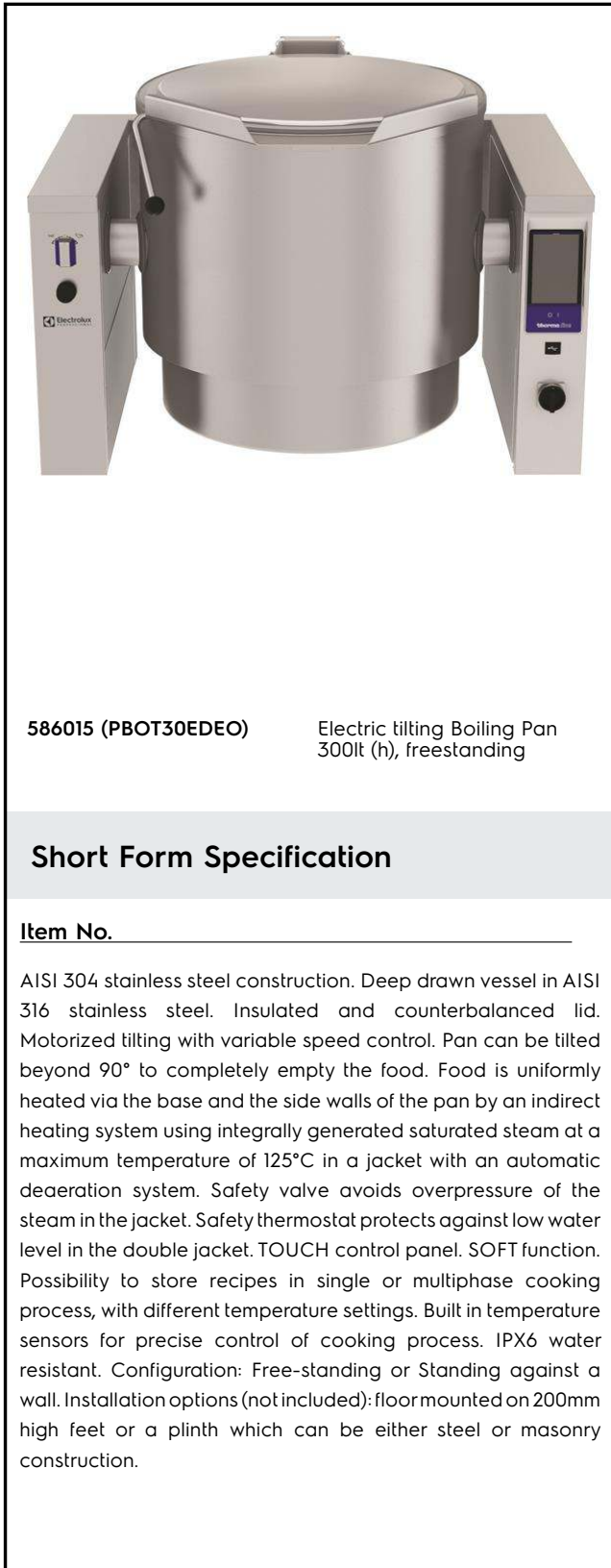
586015 (PBOT30EDEO)

 Electric tilting Boiling Pan
 300lt (h), freestanding

Short Form Specification

Item No.

AISI 304 stainless steel construction. Deep drawn vessel in AISI 316 stainless steel. Insulated and counterbalanced lid. Motorized tilting with variable speed control. Pan can be tilted beyond 90° to completely empty the food. Food is uniformly heated via the base and the side walls of the pan by an indirect heating system using integrally generated saturated steam at a maximum temperature of 125°C in a jacket with an automatic deaeration system. Safety valve avoids overpressure of the steam in the jacket. Safety thermostat protects against low water level in the double jacket. TOUCH control panel. SOFT function. Possibility to store recipes in single or multiphase cooking process, with different temperature settings. Built in temperature sensors for precise control of cooking process. IPX6 water resistant. Configuration: Free-standing or Standing against a wall. Installation options (not included): floor mounted on 200mm high feet or a plinth which can be either steel or masonry construction.

APPROVAL: _____

Main Features

- Kettle is suitable to boil, steam, poach, braise or simmer all kinds of produce.
- Isolated upper well rim avoids risk of harm for the user.
- Max pressure of inner jacket at 1,5 bar; minimum working pressure at 0.1 bar. Allows temperature control between 50 and 110°C.
- Ergonomic vessel dimensions, with a large diameter and shallow depth facilitates stirring and gentle food handling.
- Edge of the large pouring lip can be equipped with a strainer (option).
- Motorized, variable pan tilting with "SOFT STOP". Tilting and pouring speeds can be precisely adjusted. Pan can be tilted over 90° to facilitate pouring and cleaning operations.
- Built in temperature sensor to precisely control the cooking process.
- USB connection to easily update the software, upload/download recipes and download HACCP data.
- IPX6 water resistant.
- Connectivity ready for real time access to connected appliances from remote and data monitoring (requires optional accessory - contact the Company for more details).

Construction

- Cooking vessel in 1.4435 (AISI 316L) stainless steel featuring directional pouring lip. Double-jacket in 1.4404 (AISI 316L) stainless steel designed to operate at a pressure of 1.5 bar.
- External panelling and internal frame made of 1.4301 (AISI 304) stainless steel.
- Double-lined insulated lid in 1.4301 (AISI 304) stainless steel mounted on the cross beam of the unit, counterbalanced by a hinge that remains open in all positions.
- Safety valve avoids overpressure of the steam in the double jacket.
- Safety thermostat protects against low water level in the double jacket.
- Ergonomic and user friendly thanks to the high tilting position and the pouring lip design which allow to easily fill containers.
- Water mixing tap is available as optional accessory to make water filling and pan cleaning easier.
- Front-mounted inclined led "TOUCH" control panel with recessed deep drawn casing, features self-explanatory display functions which guide operator throughout the cooking process: simultaneous display of actual and set temperature as well as set cooking time and remaining cooking time; real time clock;

“SOFT” control for gentle heating up for delicate food; 9 power simmering levels from gentle to heavy boiling; timer for deferred start; error display for quick trouble-shooting.

- Minimised presence of narrow gaps for easier cleaning of the sides to meet the highest hygiene standards.
- Can be prearranged for energy optimisation or external surveillance systems (optional).
- Possibility to store recipes in single or multiphase cooking process, with different temperature settings.
- 98% recyclable by weight; packaging material free of toxic substances.

Optional Accessories

- | | | | | | |
|---|------------|--------------------------|--|------------|--------------------------|
| • Strainer for 300, 400 and 500lt tilting boiling pans | PNC 910006 | <input type="checkbox"/> | • Power Socket, CEE16, built-in, 16A/230V, IP67, blue-white - factory fitted | PNC 912474 | <input type="checkbox"/> |
| • Base plate for 300, 400 and 500lt boiling pans | PNC 910036 | <input type="checkbox"/> | • Power Socket, TYP23, built-in, 16A/230V, IP54, blue - factory fitted | PNC 912475 | <input type="checkbox"/> |
| • Measuring rod for 300lt tilting boiling pans | PNC 910047 | <input type="checkbox"/> | • Power Socket, SCHUKO, built-in, 16A/230V, IP54, blue - factory fitted | PNC 912476 | <input type="checkbox"/> |
| • Strainer for dumplings for 300, 400 and 500lt tilting boiling pans | PNC 910057 | <input type="checkbox"/> | • Power Socket, TYP25, built-in, 16A/400V, IP54, red-white - factory fitted | PNC 912477 | <input type="checkbox"/> |
| • Scraper for dumpling strainer for boiling and braising pans | PNC 910058 | <input type="checkbox"/> | • Panelling for plinth recess (depth from 70 to 270mm) for tilting units - factory fitted (Deutschland, Austria, Switzerland) - factory fitted | PNC 912479 | <input type="checkbox"/> |
| • Food tap strainer rod for stationary round boiling pans | PNC 910162 | <input type="checkbox"/> | • Manometer for tilting boiling pans - factory fitted | PNC 912490 | <input type="checkbox"/> |
| • Bottom plate with 2 feet, 200mm for tilting units (height 700mm) - factory fitted | PNC 911475 | <input type="checkbox"/> | • Rear closing kit for tilting units - against wall - factory fitted | PNC 912707 | <input type="checkbox"/> |
| • Stainless steel plinth for tilting units - against wall - factory fitted | PNC 911812 | <input type="checkbox"/> | • Automatic water filling for tilting units (cold) - to be ordered with water mixer - factory fitted | PNC 912733 | <input type="checkbox"/> |
| • Stainless steel plinth for tilting units - freestanding - factory fitted | PNC 911813 | <input type="checkbox"/> | • Automatic water filling (hot and cold) for tilting units - to be ordered with water mixer - factory fitted | PNC 912735 | <input type="checkbox"/> |
| • FOOD TAP STRAINER - PBOT | PNC 911966 | <input type="checkbox"/> | • Kit energy optimization and potential free contact - factory fitted | PNC 912737 | <input type="checkbox"/> |
| • C-board (length 1500mm) for tilting units - factory fitted | PNC 912187 | <input type="checkbox"/> | • Rear closing kit for tilting units - island type - factory fitted | PNC 912747 | <input type="checkbox"/> |
| • Power Socket, CEE16, built-in, 16A/400V, IP67, red-white - factory fitted | PNC 912468 | <input type="checkbox"/> | • Lower rear backpanel for tilting units with or without backsplash - factory fitted | PNC 912771 | <input type="checkbox"/> |
| • Power Socket, CEE32, built-in, 32A/400V, IP67, red-white - factory fitted | PNC 912469 | <input type="checkbox"/> | • Mainswitch 60A, 10mm ² - factory fitted | PNC 912774 | <input type="checkbox"/> |
| • Power Socket, SCHUKO, built-in, 16A/230V, IP68, blue-white - factory fitted | PNC 912470 | <input type="checkbox"/> | • Spray gun for tilting units - freestanding (height 700mm) - factory fitted | PNC 912776 | <input type="checkbox"/> |
| • Power Socket, TYP23, built-in, 16A/230V, IP55, black - factory fitted | PNC 912471 | <input type="checkbox"/> | • Food tap 2" for tilting boiling pans (PBOT) - factory fitted | PNC 912779 | <input type="checkbox"/> |
| • Power Socket, TYP25, built-in, 16A/400V, IP55, black - factory fitted | PNC 912472 | <input type="checkbox"/> | • External touch control device for tilting units - factory fitted | PNC 912782 | <input type="checkbox"/> |
| • Power Socket, SCHUKO, built-in, 16A/230V, IP55, black - factory fitted | PNC 912473 | <input type="checkbox"/> | • Emergency stop button - factory fitted | PNC 912784 | <input type="checkbox"/> |
| | | | • Mixing tap with drip stop, two knobs, 815mm height, 600mm swivelling depth for PBOT/PFET - factory fitted | PNC 913554 | <input type="checkbox"/> |
| | | | • Mixing tap with drip stop, two knobs, 815mm height, 450mm swivelling depth for PBOT/PFET - factory fitted | PNC 913555 | <input type="checkbox"/> |
| | | | • Mixing tap with drip stop, two knobs, 685mm height, 600mm swivelling depth for PBOT/PFET - factory fitted | PNC 913556 | <input type="checkbox"/> |
| | | | • Mixing tap with drip stop, two knobs, 685mm height, 450mm swivelling depth for PBOT/PFET - factory fitted | PNC 913557 | <input type="checkbox"/> |

- Mixing tap with drip stop, one lever, 815mm height, 600mm swivelling depth for PBOT/PFET - factory fitted PNC 913558
- Mixing tap with drip stop, one lever, 815mm height, 450mm swivelling depth for PBOT/PFET - factory fitted PNC 913559
- Mixing tap with drip stop, one lever, 685mm height, 600mm swivelling depth for PBOT/PFET - factory fitted PNC 913560
- Mixing tap with drip stop, one lever, 685mm height, 450mm swivelling depth for PBOT/PFET - factory fitted PNC 913561
- Mixing tap with two knobs, 520mm height, 600mm swivelling depth for PXXT- KWC - factory fitted PNC 913567
- Mixing tap with one lever, 564mm height, 450mm swivelling depth for PXXT- KWC - factory fitted PNC 913568
- Connectivity kit for ProThermetic Boiling and Braising Pans ECAP - factory fitted PNC 913577

Front

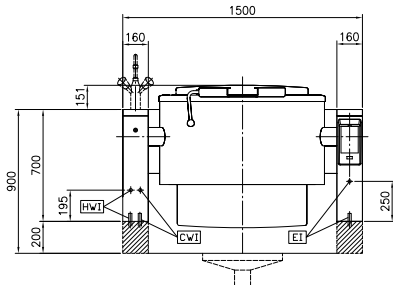

Side

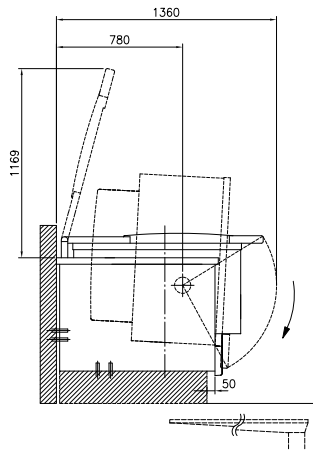

CWI = Cold Water inlet 1 (cleaning)
 EI = Electrical inlet (power)
 HWI = Hot water inlet

Top

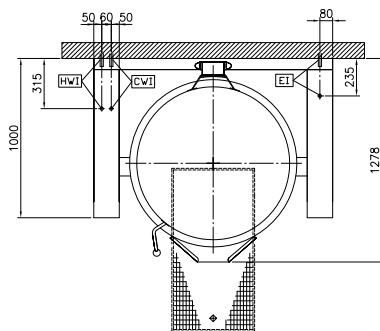

Electric

Supply voltage:

586015 (PBOT30EDEO) 400 V/3N ph/50/60 Hz

Total Watts:

36.2 kW

Installation:

FS on concrete base; FS on feet; On base; Standing against wall

Type of installation:

Key Information:

Configuration:	Round; Tilting
Working Temperature MIN:	50 °C
Working Temperature MAX:	110 °C
Vessel (round) diameter:	900 mm
Vessel (round) depth:	570 mm
External dimensions, Width:	1500 mm
External dimensions, Depth:	1000 mm
External dimensions, Height:	700 mm
Net weight:	390 kg
Net vessel useful capacity:	300 lt
Tilting mechanism:	Automatic
Double jacketed lid:	✓
Heating type:	Indirect

Energy Consumption

Standard:

Item heated:	0 lt
Heat up temperature:	From 0°C to 0°C
Heat up time:	0 min
Energy consumed in heat up phase:	0
Energy efficiency:	0 %