

High Productivity Cooking Electric Tilting Boiling Pan, 150lt Hygienic Profile, Freestanding with Stirrer

ITEM # _____

MODEL # _____

NAME # _____

SIS # _____

AIA # _____

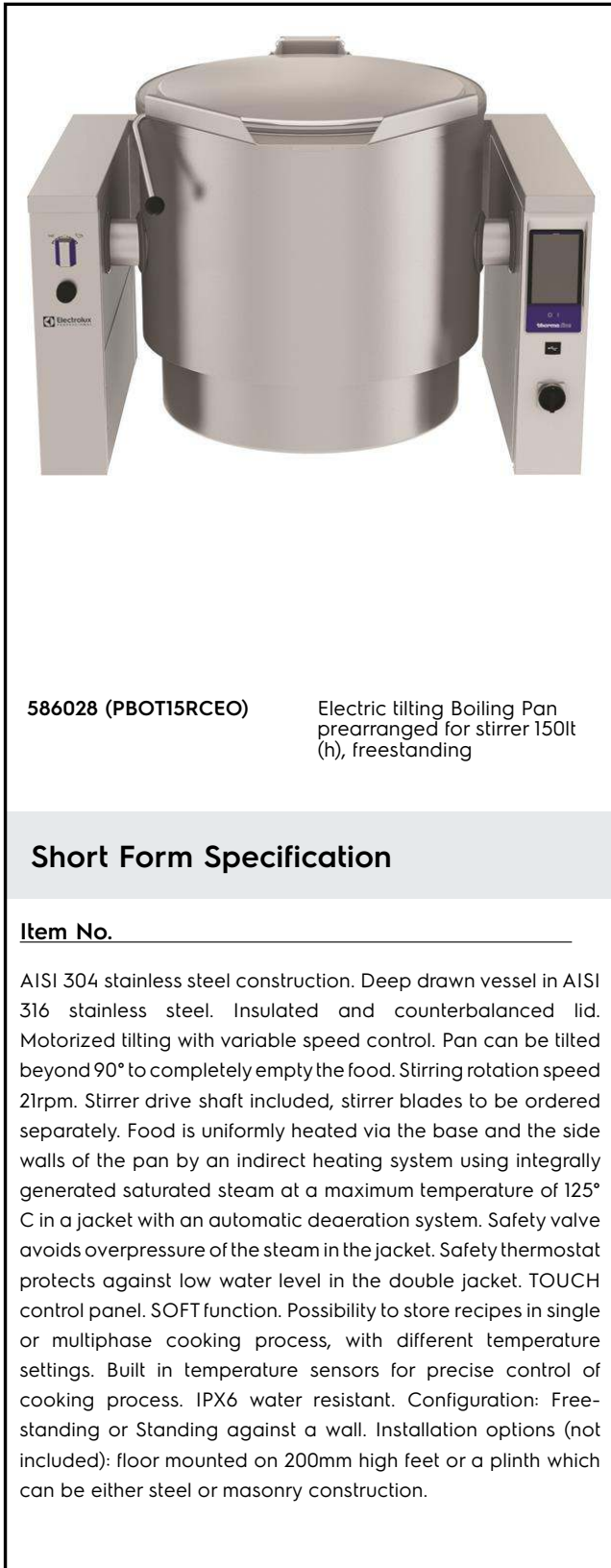
586028 (PBOT15RCEO)

 Electric tilting Boiling Pan
 prearranged for stirrer 150lt
 (h), freestanding

Short Form Specification

Item No.

AISI 304 stainless steel construction. Deep drawn vessel in AISI 316 stainless steel. Insulated and counterbalanced lid. Motorized tilting with variable speed control. Pan can be tilted beyond 90° to completely empty the food. Stirring rotation speed 21rpm. Stirrer drive shaft included, stirrer blades to be ordered separately. Food is uniformly heated via the base and the side walls of the pan by an indirect heating system using integrally generated saturated steam at a maximum temperature of 125° C in a jacket with an automatic deaeration system. Safety valve avoids overpressure of the steam in the jacket. Safety thermostat protects against low water level in the double jacket. TOUCH control panel. SOFT function. Possibility to store recipes in single or multiphase cooking process, with different temperature settings. Built in temperature sensors for precise control of cooking process. IPX6 water resistant. Configuration: Free-standing or Standing against a wall. Installation options (not included): floor mounted on 200mm high feet or a plinth which can be either steel or masonry construction.

APPROVAL: _____

Main Features

- Kettle is suitable to boil, steam, poach, braise or simmer all kinds of produce.
- Max pressure of inner jacket at 1,5 bar; minimum working pressure at 0.1 bar. Allows temperature control between 50 and 110°C.
- Kettle is jacketed up to 159 mm from upper rim.
- Isolated upper well rim avoids risk of harm for the user.
- Ergonomic vessel dimensions, with a large diameter and shallow depth facilitates stirring and gentle food handling.
- Edge of the large pouring lip can be equipped with a strainer (option).
- Motorized, variable pan tilting with "SOFT STOP". Tilting and pouring speeds can be precisely adjusted. Pan can be tilted over 90° to facilitate pouring and cleaning operations.
- Built in temperature sensor to precisely control the cooking process.
- USB connection to easily update the software, upload/download recipes and download HACCP data.
- IPX6 water resistant.
- Connectivity ready for real time access to connected appliances from remote and data monitoring (requires optional accessory - contact the Company for more details).

Construction

- Cooking vessel in 1.4435 (AISI 316L) stainless steel featuring directional pouring lip. Double-jacket in 1.4404 (AISI 316L) stainless steel designed to operate at a pressure of 1.5 bar.
- External panelling and internal frame made of 1.4301 (AISI 304) stainless steel.
- Double-lined insulated lid in 1.4301 (AISI 304) stainless steel mounted on the cross beam of the unit, counterbalanced by a hinge that remains open in all positions.
- Safety valve avoids overpressure of the steam in the double jacket.
- Stirrer with rotation speed of 22 RPMs.
- Safety thermostat protects against low water level in the double jacket.
- Water mixing tap is available as optional accessory to make water filling and pan cleaning easier.
- Ergonomic and user friendly thanks to the high tilting position and the pouring lip design which allow to easily fill containers.
- Front-mounted inclined led "TOUCH" control panel with recessed deep drawn casing, features self-explanatory display functions which guide operator throughout the cooking process: simultaneous display of actual and

set temperature as well as set cooking time and remaining cooking time; real time clock; "SOFT" control for gentle heating up for delicate food; 9 power simmering levels from gentle to heavy boiling; timer for deferred start; error display for quick trouble-shooting.

- Minimised presence of narrow gaps for easier cleaning of the sides to meet the highest hygiene standards.
- Can be prearranged for energy optimisation or external surveillance systems (optional).
- Possibility to store recipes in single or multiphase cooking process, with different temperature settings.
- 98% recyclable by weight; packaging material free of toxic substances.

Included Accessories

- 1 of Emergency stop button - factory fitted PNC 912784

Optional Accessories

- Strainer for 150lt tilting boiling pans PNC 910004
- Measuring rod for 150lt tilting boiling pans PNC 910045
- Grid stirrer for 150lt boiling pans PNC 910064
- Grid stirrer and scraper for 150lt boiling pans PNC 910094
- Food tap strainer rod for stationary round boiling pans PNC 910162
- Stainless steel plinth for tilting units - against wall - factory fitted PNC 911425
- Stainless steel plinth for tilting units - freestanding - factory fitted PNC 911455
- Bottom plate with 2 feet, 200mm for tilting units (height 700mm) - factory fitted PNC 911930
- FOOD TAP STRAINER - PBOT PNC 911966
- C-board (length 1300mm) for tilting units - factory fitted PNC 912185
- MOBILE KIT TxxT/PxxT (VAR. width=S-Code) PNC 912460
- Power Socket, CEE16, built-in, 16A/400V, IP67, red-white - factory fitted PNC 912468
- Power Socket, CEE32, built-in, 32A/400V, IP67, red-white - factory fitted PNC 912469
- Power Socket, SCHUKO, built-in, 16A/230V, IP68, blue-white - factory fitted PNC 912470
- Power Socket, TYP23, built-in, 16A/230V, IP55, black - factory fitted PNC 912471
- Power Socket, TYP25, built-in, 16A/400V, IP55, black - factory fitted PNC 912472

- Power Socket, SCHUKO, built-in, 16A/230V, IP55, black - factory fitted PNC 912473
- Power Socket, CEE16, built-in, 16A/230V, IP67, blue-white - factory fitted PNC 912474
- Power Socket, TYP23, built-in, 16A/230V, IP54, blue - factory fitted PNC 912475
- Power Socket, SCHUKO, built-in, 16A/230V, IP54, blue - factory fitted PNC 912476
- Power Socket, TYP25, built-in, 16A/400V, IP54, red-white - factory fitted PNC 912477
- Panelling for plinth recess (depth from 70 to 270mm) for tilting units - factory fitted (Deutschland, Austria, Switzerland) - factory fitted PNC 912479
- Additional panelling plinth for tilting units (width 120mm) - factory fitted (Deutschland, Austria, Switzerland) PNC 912486
- Manometer for tilting boiling pans - factory fitted PNC 912490
- Connecting rail kit for appliances with backsplash, 900mm PNC 912499
- Connecting rail kit, 900mm PNC 912502
- Rear closing kit for tilting units - against wall - factory fitted PNC 912705
- Automatic water filling for tilting units (cold) - to be ordered with water mixer - factory fitted PNC 912733
- Automatic water filling (hot and cold) for tilting units - to be ordered with water mixer - factory fitted PNC 912735
- Kit energy optimization and potential free contact - factory fitted PNC 912737
- Mainswitch 60A, 6mm² - factory fitted PNC 912740
- Rear closing kit for tilting units - island type - factory fitted PNC 912745
- Lower rear backpanel for tilting units with or without backsplash - factory fitted PNC 912769
- Spray gun for tilting units - freestanding (height 700mm) - factory fitted PNC 912776
- Food tap 2" for tilting boiling pans (PBOT) - factory fitted PNC 912779
- External touch control device for tilting units - factory fitted PNC 912782
- Connecting rail kit: modular 90 (on the left) to ProThermetic tilting (on the right), ProThermetic stationary (on the left) to ProThermetic tilting (on the right) PNC 912975
- Connecting rail kit: modular 80 (on the right) to ProThermetic tilting (on the left), ProThermetic stationary (on the right) to ProThermetic tilting (on the left) PNC 912976

- Connecting rail kit for appliances with backsplash: modular 90 (on the left) to ProThermetic tilting (on the right), ProThermetic stationary (on the left) to ProThermetic tilting (on the right) PNC 912981
- Connecting rail kit for appliances with backsplash: modular 90 (on the right) to ProThermetic tilting (on the left), ProThermetic stationary (on the right) to ProThermetic tilting (on the left) PNC 912982
- Mixing tap with drip stop, two knobs, 815mm height, 600mm swivelling depth for PBOT/PFET - factory fitted PNC 913554
- Mixing tap with drip stop, two knobs, 815mm height, 450mm swivelling depth for PBOT/PFET - factory fitted PNC 913555
- Mixing tap with drip stop, two knobs, 685mm height, 600mm swivelling depth for PBOT/PFET - factory fitted PNC 913556
- Mixing tap with drip stop, two knobs, 685mm height, 450mm swivelling depth for PBOT/PFET - factory fitted PNC 913557
- Mixing tap with drip stop, one lever, 815mm height, 600mm swivelling depth for PBOT/PFET - factory fitted PNC 913558
- Mixing tap with drip stop, one lever, 815mm height, 450mm swivelling depth for PBOT/PFET - factory fitted PNC 913559
- Mixing tap with drip stop, one lever, 685mm height, 600mm swivelling depth for PBOT/PFET - factory fitted PNC 913560
- Mixing tap with drip stop, one lever, 685mm height, 450mm swivelling depth for PBOT/PFET - factory fitted PNC 913561
- Mixing tap with two knobs, 520mm height, 600mm swivelling depth for PXXT- KWC - factory fitted PNC 913567
- Mixing tap with one lever, 564mm height, 450mm swivelling depth for PXXT- KWC - factory fitted PNC 913568
- Connectivity kit for ProThermetic Boiling and Braising Pans ECAP - factory fitted PNC 913577

Front

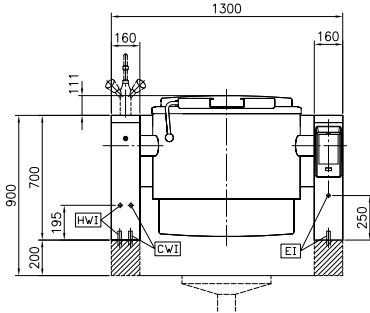

Side

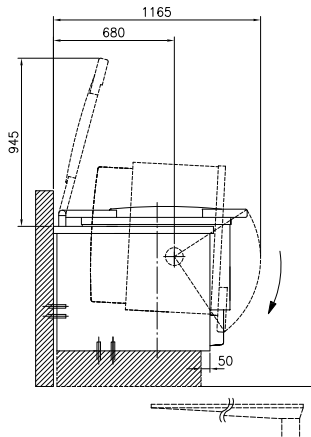

CWI = Cold Water inlet (cleaning)
 EI = Electrical inlet (power)
 HWI = Hot water inlet

Top

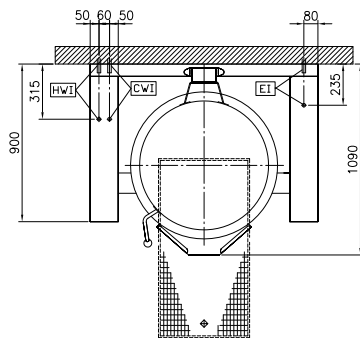

Electric

Supply voltage:

586028 (PBOT15RCEO) 400 V/3N ph/50/60 Hz

Total Watts:

24.6 kW

Installation:

FS on concrete base; FS on feet; On base; Standing against wall

Type of installation:

Key Information:

Configuration:	Round, tilting, with stirrer
Working Temperature MIN:	50 °C
Working Temperature MAX:	110 °C
Vessel (round) diameter:	710 mm
Vessel (round) depth:	465 mm
External dimensions, Width:	1300 mm
External dimensions, Depth:	900 mm
External dimensions, Height:	700 mm
Net weight:	290 kg
Net vessel useful capacity:	150 lt
Tilting mechanism:	Automatic
Double jacketed lid:	✓
Heating type:	Indirect

Energy Consumption

Standard:	DIN18855-1: 2005-07
Item heated:	150 lt Water
Heat up temperature:	From 20°C to 90°C
Heat up time:	32.6 min
Energy consumed in heat up phase:	12.91 kWh
Energy efficiency:	94.58 %