

SkyLine Pro LPG Gas Combi Oven 10GN2/1

ITEM # _____

MODEL # _____

NAME # _____

SIS # _____

AIA # _____



Short Form Specification

Item No.

- Combi oven with digital interface with guided selection.
- Boilerless steaming function to add and retain moisture.
 - OptiFlow air distribution system to achieve maximum performance with 5 fan speed levels.
 - SkyClean: Automatic and built-in self cleaning system. 5 automatic cycles (soft, medium, strong, extra strong, rinse-only).
 - Cooking modes: Programs (a maximum of 100 recipes can be stored); Manual; EcoDelta cooking cycle.
 - Automatic backup mode to avoid downtime.
 - USB port to download HACCP data, programs and settings. Connectivity ready.
 - Single sensor core temperature probe.
 - Double-glass door with LED lights.
 - Stainless steel construction throughout.
 - Supplied with n.1 tray rack 2/1 GN, 67 mm pitch.

Main Features

- Digital interface with LED backlight buttons with guided selection.
- Boilerless steaming function to add and retain moisture for high quality, consistent cooking results.
- Dry hot convection cycle (max 300 °C) ideal for low humidity cooking. Automatic moistener (11 settings) for boiler-less steam generation.
- EcoDelta cooking: cooking with food probe maintaining preset temperature difference between the core of the food and the cooking chamber.
- Programs mode: a maximum of 100 recipes can be stored in the oven's memory, to recreate the exact same recipe at any time. 4-step cooking programs also available.
- Fan with 5 speed levels from 300 to 1500 RPM and reverse rotation for optimal evenness. Fan stops in less than 5 seconds when door is opened.
- Single sensor core temperature probe included.
- Automatic fast cool down and pre-heat function.
- SkyClean: Automatic and built-in self cleaning system. 5 automatic cycles (soft, medium, strong, extra strong, rinse-only).
- Different chemical options available: solid (phosphate-free), liquid (requires optional accessory).
- GreaseOut: predisposed for integrated grease drain and collection for safer operation (dedicated base as optional accessory).
- USB port to download HACCP data, share cooking programs and configurations. USB port also allows to plug-in sous-vide probe (optional accessory).
- Connectivity ready for real time access to connected appliances from remote and HACCP monitoring (requires optional accessory).
- Back-up mode with self-diagnosis is automatically activated if a failure occurs to avoid downtime.
- Capacity: 10 GN 2/1 or 20 GN 1/1 trays.
- Connectivity ready for real time access to connected appliances from remote and data monitoring (requires optional accessory - contact the Company for more details).
- OptiFlow air distribution system to achieve maximum performance in chilling/heating evenness and temperature control thanks to a special design of the chamber.

Construction

- Human centered design with 4-star certification for ergonomics and usability.
- Wing-shaped handle with ergonomic design and hands-free opening with the elbow, making managing trays simpler. Protected by registered design (EM003143551 and related family).
- Double thermo-glazed door with open frame construction, for cool outside door panel. Swing hinged easy-release inner glass on door for easy cleaning.
- Seamless hygienic internal chamber with all rounded corners for easy cleaning.
- 304 AISI stainless steel construction throughout.

APPROVAL: _____

- Front access to control board for easy service.
- IPX 5 spray water protection certification for easy cleaning.
- Supplied with n.1 tray rack 2/1 GN, 67 mm pitch.

Optional Accessories

- | | | | | | |
|---|------------|--------------------------|--|------------|--------------------------|
| • Water softener with cartridge and flow meter (high steam usage) | PNC 920003 | <input type="checkbox"/> | • Bakery/pastry tray rack with wheels 400x600mm for 10 GN 2/1 oven and blast chiller freezer, 80mm pitch (8 runners) | PNC 922609 | <input type="checkbox"/> |
| • Water filter with cartridge and flow meter for 6 & 10 GN 1/1 ovens (low-medium steam usage - less than 2hrs per day full steam) | PNC 920004 | <input type="checkbox"/> | • Open base with tray support for 6 & 10 GN 2/1 oven | PNC 922613 | <input type="checkbox"/> |
| • Water softener with salt for ovens with automatic regeneration of resin | PNC 921305 | <input type="checkbox"/> | • Cupboard base with tray support for 6 & 10 GN 2/1 oven | PNC 922616 | <input type="checkbox"/> |
| • Wheel kit for 6 & 10 GN 1/1 and 2/1 GN oven base (not for the disassembled one) | PNC 922003 | <input type="checkbox"/> | • External connection kit for liquid detergent and rinse aid | PNC 922618 | <input type="checkbox"/> |
| • Pair of AISI 304 stainless steel grids, GN 1/1 | PNC 922017 | <input type="checkbox"/> | • Stacking kit for 6 GN 2/1 oven placed on gas 6 GN 2/1 oven | PNC 922625 | <input type="checkbox"/> |
| • Pair of grids for whole chicken (8 per grid - 1,2kg each), GN 1/1 | PNC 922036 | <input type="checkbox"/> | • Trolley for slide-in rack for 10 GN 2/1 oven and blast chiller freezer | PNC 922627 | <input type="checkbox"/> |
| • AISI 304 stainless steel grid, GN 1/1 | PNC 922062 | <input type="checkbox"/> | • Trolley for mobile rack for 6 GN 2/1 on 6 or 10 GN 2/1 ovens | PNC 922631 | <input type="checkbox"/> |
| • AISI 304 stainless steel grid, GN 2/1 | PNC 922076 | <input type="checkbox"/> | • Stainless steel drain kit for 6 & 10 GN oven, dia=50mm | PNC 922636 | <input type="checkbox"/> |
| • External side spray unit (needs to be mounted outside and includes support to be mounted on the oven) | PNC 922171 | <input type="checkbox"/> | • Plastic drain kit for 6 & 10 GN oven, dia=50mm | PNC 922637 | <input type="checkbox"/> |
| • Pair of AISI 304 stainless steel grids, GN 2/1 | PNC 922175 | <input type="checkbox"/> | • Trolley with 2 tanks for grease collection | PNC 922638 | <input type="checkbox"/> |
| • Baking tray for 5 baguettes in perforated aluminum with silicon coating, 400x600x38mm | PNC 922189 | <input type="checkbox"/> | • Grease collection kit for GN 1/1-2/1 open base (2 tanks, open/close device for drain) | PNC 922639 | <input type="checkbox"/> |
| • Baking tray with 4 edges in perforated aluminum, 400x600x20mm | PNC 922190 | <input type="checkbox"/> | • Banquet rack with wheels holding 51 plates for 10 GN 2/1 oven and blast chiller freezer, 75mm pitch | PNC 922650 | <input type="checkbox"/> |
| • Baking tray with 4 edges in aluminum, 400x600x20mm | PNC 922191 | <input type="checkbox"/> | • Dehydration tray, GN 1/1, H=20mm | PNC 922651 | <input type="checkbox"/> |
| • Pair of frying baskets | PNC 922239 | <input type="checkbox"/> | • Flat dehydration tray, GN 1/1 | PNC 922652 | <input type="checkbox"/> |
| • AISI 304 stainless steel bakery/pastry grid 400x600mm | PNC 922264 | <input type="checkbox"/> | • Open base for 6 & 10 GN 2/1 oven, disassembled - NO accessory can be fitted with the exception of 922384 | PNC 922654 | <input type="checkbox"/> |
| • Double-step door opening kit | PNC 922265 | <input type="checkbox"/> | • Heat shield for 10 GN 2/1 oven | PNC 922664 | <input type="checkbox"/> |
| • Grid for whole chicken (8 per grid - 1,2kg each), GN 1/1 | PNC 922266 | <input type="checkbox"/> | • Heat shield-stacked for ovens 6 GN 2/1 on 10 GN 2/1 | PNC 922667 | <input type="checkbox"/> |
| • Kit universal skewer rack and 6 short skewers for Lengthwise and Crosswise ovens | PNC 922325 | <input type="checkbox"/> | • Kit to convert from natural gas to LPG | PNC 922670 | <input type="checkbox"/> |
| • Universal skewer rack | PNC 922326 | <input type="checkbox"/> | • Kit to convert from LPG to natural gas | PNC 922671 | <input type="checkbox"/> |
| • 6 short skewers | PNC 922328 | <input type="checkbox"/> | • Flue condenser for gas oven | PNC 922678 | <input type="checkbox"/> |
| • Multipurpose hook | PNC 922348 | <input type="checkbox"/> | • Kit to fix oven to the wall | PNC 922687 | <input type="checkbox"/> |
| • 4 flanged feet for 6 & 10 GN , 2", 100-130mm | PNC 922351 | <input type="checkbox"/> | • Tray support for 6 & 10 GN 2/1 oven base | PNC 922692 | <input type="checkbox"/> |
| • Grease collection tray, GN 2/1, H=60 mm | PNC 922357 | <input type="checkbox"/> | • 4 adjustable feet with black cover for 6 & 10 GN ovens, 100-115mm | PNC 922693 | <input type="checkbox"/> |
| • Grid for whole duck (8 per grid - 1,8kg each), GN 1/1 | PNC 922362 | <input type="checkbox"/> | • Connectivity WiFi board (NIU-HACL) for SkyLine/Magistar and Rapido | PNC 922695 | <input type="checkbox"/> |
| • Thermal cover for 10 GN 2/1 oven and blast chiller freezer | PNC 922366 | <input type="checkbox"/> | • Ethernet board (NIU-LAN) for Ovens and green&clean Rack Type Dishwashers | PNC 922696 | <input type="checkbox"/> |
| • Tray support for 6 & 10 GN 2/1 disassembled open base | PNC 922384 | <input type="checkbox"/> | • Detergent tank holder for open base | PNC 922699 | <input type="checkbox"/> |
| • Wall mounted detergent tank holder | PNC 922386 | <input type="checkbox"/> | • Mesh grilling grid, GN 1/1 | PNC 922713 | <input type="checkbox"/> |
| • USB single point probe | PNC 922390 | <input type="checkbox"/> | • Probe holder for liquids | PNC 922714 | <input type="checkbox"/> |
| • Tray rack with wheels 10 GN 2/1, 65mm pitch | PNC 922603 | <input type="checkbox"/> | • Exhaust hood with fan for 6 & 10 GN 2/1 GN ovens | PNC 922729 | <input type="checkbox"/> |
| • Tray rack with wheels, 8 GN 2/1, 80mm pitch | PNC 922604 | <input type="checkbox"/> | • Exhaust hood with fan for stacking 6+6 or 6+10 GN 2/1 ovens | PNC 922731 | <input type="checkbox"/> |
| • Slide-in rack with handle for 6 & 10 GN 2/1 oven | PNC 922605 | <input type="checkbox"/> | • Exhaust hood without fan for 6&10x2/1 GN oven | PNC 922734 | <input type="checkbox"/> |
| | | | • Exhaust hood without fan for stacking 6+6 or 6+10 GN 2/1 ovens | PNC 922736 | <input type="checkbox"/> |
| | | | • 4 high adjustable feet for 6 & 10 GN ovens, 230-290mm | PNC 922745 | <input type="checkbox"/> |

- Tray for traditional static cooking, H=100mm PNC 922746
- Double-face griddle, one side ribbed and one side smooth, 400x600mm PNC 922747
- Trolley for grease collection kit PNC 922752
- Water inlet pressure reducer PNC 922773
- Extension for condensation tube, 37cm PNC 922776
- Non-stick universal pan, GN 1/1, H=20mm PNC 925000
- Non-stick universal pan, GN 1/1, H=40mm PNC 925001
- Non-stick universal pan, GN 1/1, H=60mm PNC 925002
- Double-face griddle, one side ribbed and one side smooth, GN 1/1 PNC 925003
- Aluminum grill, GN 1/1 PNC 925004
- Frying pan for 8 eggs, pancakes, hamburgers, GN 1/1 PNC 925005
- Flat baking tray with 2 edges, GN 1/1 PNC 925006
- Potato baker for 28 potatoes, GN 1/1 PNC 925008
- Compatibility kit for installation on previous base GN 2/1 PNC 930218

Front

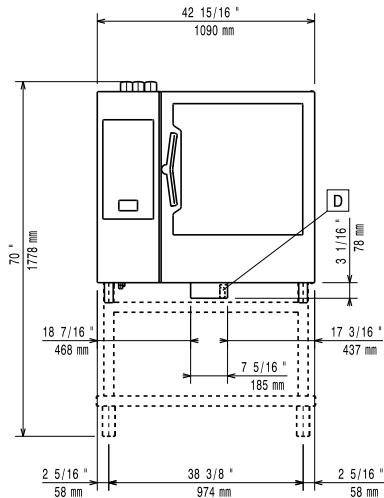

Side

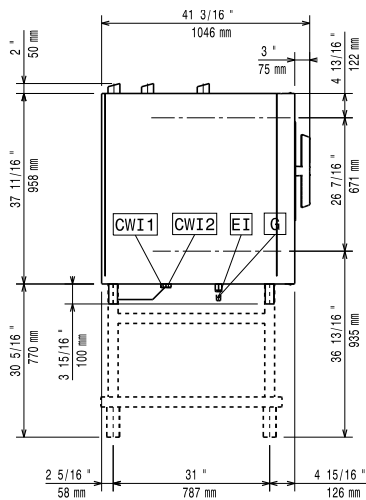

CWI1 = Cold Water inlet 1 (cleaning) EI = Electrical inlet (power)
 CWI2 = Cold Water Inlet 2 (steam generator) G = Gas connection
 D = Drain
 DO = Overflow drain pipe

Top

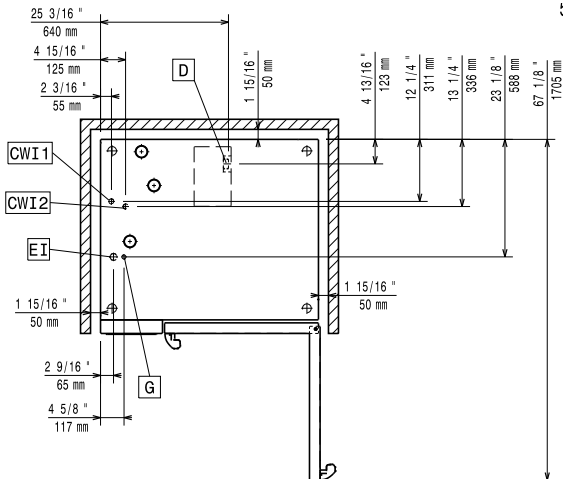

Electric

Supply voltage:

217963 (ECO102C2H0) 220-240 V/1 ph/50 Hz

Electrical power, default: 1.5 kW

Default power corresponds to factory test conditions. When supply voltage is declared as a range the test is performed at the average value. According to the country, the installed power may vary within the range.

Electrical power max.: 1.5 kW

Circuit breaker required

Gas

Gas Power: 35 kW

Standard gas delivery: LPG, G31

ISO 7/1 gas connection diameter: 1/2" MNPT

LPG:

Total thermal load: 119315 BTU (35 kW)

Water:

Water inlet connections "CWI1-CWI2": 3/4"

Pressure, bar min/max: 1-6 bar

Drain "D": 50mm

Max inlet water supply temperature: 30 °C

Hardness: 5 °fH / 2.8 °dH

Chlorides: <10 ppm

Conductivity: >50 µS/cm

Electrolux Professional recommends the use of treated water, based on testing of specific water conditions.

Please refer to user manual for detailed water quality information.

Installation:

Clearance: Clearance: 5 cm rear and right hand sides.

Suggested clearance for service access: 50 cm left hand side.

Capacity:

Trays type: 10 - 2/1 Gastronorm

Max load capacity: 100 kg

Key Information:

Door hinges:

External dimensions, Width: 1090 mm

External dimensions, Depth: 971 mm

External dimensions, Height: 1058 mm

Net weight: 175 kg

Shipping weight: 200 kg

Shipping volume: 1.58 m³