

SkyLine Premium LPG Gas Combi Oven 6GN2/1

ITEM # _____

MODEL # _____

NAME # _____

SIS # _____

AIA # _____

217861 (ECOG62B2H0)

SkyLine Premium Combi Boiler Oven with digital control, 6x2/1GN, gas, programmable, automatic cleaning, LPG

Short Form Specification

Item No.

- Combi oven with digital interface with guided selection.
- Built-in steam generator with real humidity control based upon Lambda Sensor.
 - OptiFlow air distribution system to achieve maximum performance with 5 fan speed levels.
 - SkyClean: Automatic and built-in self cleaning system with integrated descale of the steam generator. 5 automatic cycles (soft, medium, strong, extra strong, rinse-only).
 - Cooking modes: Programs (a maximum of 100 recipes can be stored); Manual (steam, combi and convection cycles); EcoDelta cooking cycle; Regeneration cycle.
 - Automatic backup mode to avoid downtime.
 - USB port to download HACCP data, programs and settings. Connectivity ready.
 - Single sensor core temperature probe.
 - Double-glass door with LED lights.
 - Stainless steel construction throughout.
 - Supplied with n.1 tray rack 2/1 GN, 67 mm pitch.

Main Features

- Digital interface with LED backlight buttons with guided selection.
- Built-in steam generator for highly precise humidity and temperature control according to the chosen settings.
- Real humidity control based upon Lambda Sensor to automatically recognize quantity and size of food for consistent quality results.
- Dry, hot convection cycle (25 °C - 300 °C): ideal for low humidity cooking.
- Combination cycle (25 °C - 300 °C): combining convected heat and steam to obtain humidity controlled cooking environment, accelerating the cooking process and reducing weight loss.
- Low temperature Steam cycle (25 °C - 99 °C): ideal for sous-vide, re-thermalization and delicate cooking.
 Steam cycle (100 °C): seafood and vegetables.
 High temperature steam (25 °C - 130 °C).
- EcoDelta cooking: cooking with food probe maintaining preset temperature difference between the core of the food and the cooking chamber.
- Pre-set program for Regeneration, ideal for banqueting on plate or rethermalizing on tray.
- Programs mode: a maximum of 100 recipes can be stored in the oven's memory, to recreate the exact same recipe at any time. 4-step cooking programs also available.
- Fan with 5 speed levels from 300 to 1500 RPM and reverse rotation for optimal evenness. Fan stops in less than 5 seconds when door is opened.
- Single sensor core temperature probe included.
- Automatic fast cool down and pre-heat function.
- Reduced power function for customized slow cooking cycles.
- SkyClean: Automatic and built-in self cleaning system with integrated descale of the steam generator. 5 automatic cycles (soft, medium, strong, extra strong, rinse-only).
- Different chemical options available: solid (phosphate-free), liquid (requires optional accessory).
- GreaseOut: predisposed for integrated grease drain and collection for safer operation (dedicated base as optional accessory).
- USB port to download HACCP data, share cooking programs and configurations.
 USB port also allows to plug-in sous-vide probe (optional accessory).
- Connectivity ready for real time access to connected appliances from remote and HACCP monitoring (requires optional accessory).
- Back-up mode with self-diagnosis is automatically activated if a failure occurs to avoid downtime.
- Capacity: 6 GN 2/1 or 12 GN 1/1 trays.
- Connectivity ready for real time access to connected appliances from remote and data monitoring (requires optional accessory - contact the Company for more details).
- OptiFlow air distribution system to achieve maximum performance in chilling/heating evenness

APPROVAL: _____

and temperature control thanks to a special design of the chamber.

Construction

- Human centered design with 4-star certification for ergonomics and usability.
- Wing-shaped handle with ergonomic design and hands-free opening with the elbow, making managing trays simpler. Protected by registered design (EM003143551 and related family).
- Double thermo-glazed door with open frame construction, for cool outside door panel. Swing hinged easy-release inner glass on door for easy cleaning.
- Seamless hygienic internal chamber with all rounded corners for easy cleaning.
- 304 AISI stainless steel construction throughout.
- Front access to control board for easy service.
- IPX 5 spray water protection certification for easy cleaning.
- Supplied with n.1 tray rack 2/1 GN, 67 mm pitch.

Included Accessories

- 1 of Chimney adaptor needed in case of conversion of 6 GN 1/1 or 6 GN 2/1 ovens from natural gas to LPG PNC 922706

Optional Accessories

- External reverse osmosis filter for single tank Dishwashers with atmosphere boiler and Ovens PNC 864388
- Water softener with cartridge and flow meter (high steam usage) PNC 920003
- Water filter with cartridge and flow meter for 6 & 10 GN 1/1 ovens (low-medium steam usage - less than 2hrs per day full steam) PNC 920004
- Water softener with salt for ovens with automatic regeneration of resin PNC 921305
- Wheel kit for 6 & 10 GN 1/1 and 2/1 GN oven base (not for the disassembled one) PNC 922003
- Pair of AISI 304 stainless steel grids, GN 1/1 PNC 922017
- Pair of grids for whole chicken (8 per grid - 1,2kg each), GN 1/1 PNC 922036
- AISI 304 stainless steel grid, GN 1/1 PNC 922062
- AISI 304 stainless steel grid, GN 2/1 PNC 922076
- External side spray unit (needs to be mounted outside and includes support to be mounted on the oven) PNC 922171
- Pair of AISI 304 stainless steel grids, GN 2/1 PNC 922175
- Baking tray for 5 baguettes in perforated aluminum with silicon coating, 400x600x38mm PNC 922189
- Baking tray with 4 edges in perforated aluminum, 400x600x20mm PNC 922190
- Baking tray with 4 edges in aluminum, 400x600x20mm PNC 922191
- Pair of frying baskets PNC 922239
- AISI 304 stainless steel bakery/pastry grid 400x600mm PNC 922264
- Double-step door opening kit PNC 922265
- Grid for whole chicken (8 per grid - 1,2kg each), GN 1/1 PNC 922266

- Kit universal skewer rack and 6 short skewers for Lengthwise and Crosswise ovens PNC 922325
- Universal skewer rack PNC 922326
- 6 short skewers PNC 922328
- Volcano Smoker for lengthwise and crosswise oven PNC 922338
- Multipurpose hook PNC 922348
- 4 flanged feet for 6 & 10 GN , 2", 100-130mm PNC 922351
- Grease collection tray, GN 2/1, H=60 mm PNC 922357
- Grid for whole duck (8 per grid - 1,8kg each), GN 1/1 PNC 922362
- Tray support for 6 & 10 GN 2/1 disassembled open base PNC 922384
- Wall mounted detergent tank holder PNC 922386
- USB single point probe PNC 922390
- Slide-in rack with handle for 6 & 10 GN 2/1 oven PNC 922605
- Tray rack with wheels, 5 GN 2/1, 80mm pitch PNC 922611
- Open base with tray support for 6 & 10 GN 2/1 oven PNC 922613
- Cupboard base with tray support for 6 & 10 GN 2/1 oven PNC 922616
- Hot cupboard base with tray support for 6 & 10 GN 2/1 oven holding GN 2/1 trays PNC 922617
- External connection kit for liquid detergent and rinse aid PNC 922618
- Stacking kit for 6X2/1 GN oven on gas 6X2/1 GN oven PNC 922624
- Stacking kit for 6 GN 2/1 oven placed on gas 6 GN 2/1 oven PNC 922625
- Trolley for slide-in rack for 10 GN 2/1 oven and blast chiller freezer PNC 922627
- Trolley for mobile rack for 2 stacked 6 GN 2/1 ovens on riser PNC 922629
- Trolley for mobile rack for 6 GN 2/1 on 6 or 10 GN 2/1 ovens PNC 922631
- Riser on feet for stacked 2x6 GN 1/1 ovens PNC 922633
- Riser on wheels for stacked 2x6 GN 2/1 ovens, height 250mm PNC 922634
- Stainless steel drain kit for 6 & 10 GN oven, dia=50mm PNC 922636
- Plastic drain kit for 6 & 10 GN oven, dia=50mm PNC 922637
- Trolley with 2 tanks for grease collection PNC 922638
- Grease collection kit for GN 1/1-2/1 open base (2 tanks, open/close device for drain) PNC 922639
- Wall support for 6 GN 2/1 oven PNC 922644
- Dehydration tray, GN 1/1, H=20mm PNC 922651
- Flat dehydration tray, GN 1/1 PNC 922652
- Open base for 6 & 10 GN 2/1 oven, disassembled - NO accessory can be fitted with the exception of 922384 PNC 922654
- Heat shield for 6 GN 2/1 oven PNC 922665
- Heat shield-stacked for ovens 6 GN 2/1 on 6 GN 2/1 PNC 922666

- Heat shield-stacked for ovens 6 GN 2/1 on 10 GN 2/1 PNC 922667
- Kit to convert from natural gas to LPG PNC 922670
- Kit to convert from LPG to natural gas PNC 922671
- Flue condenser for gas oven PNC 922678
- Fixed tray rack, 5 GN 2/1, 85mm pitch PNC 922681
- Kit to fix oven to the wall PNC 922687
- Tray support for 6 & 10 GN 2/1 oven base PNC 922692
- 4 adjustable feet with black cover for 6 & 10 GN ovens, 100-115mm PNC 922693
- Connectivity WiFi board (NIU-HACL) for SkyLine/Magistar and Rapido PNC 922695
- Ethernet board (NIU-LAN) for Ovens and green&clean Rack Type Dishwashers PNC 922696
- Detergent tank holder for open base PNC 922699
- Tray rack with wheels, 6 GN 2/1, 65mm pitch PNC 922700
- Chimney adaptor needed in case of conversion of 6 GN 1/1 or 6 GN 2/1 ovens from natural gas to LPG PNC 922706
- Mesh grilling grid, GN 1/1 PNC 922713
- Probe holder for liquids PNC 922714
- Exhaust hood with fan for 6 & 10 GN 2/1 GN ovens PNC 922729
- Exhaust hood with fan for stacking 6+6 or 6+10 GN 2/1 ovens PNC 922731
- Exhaust hood without fan for 6&10x2/1 GN oven PNC 922734
- Exhaust hood without fan for stacking 6+6 or 6+10 GN 2/1 ovens PNC 922736
- 4 high adjustable feet for 6 & 10 GN ovens, 230-290mm PNC 922745
- Tray for traditional static cooking, H=100mm PNC 922746
- Double-face griddle, one side ribbed and one side smooth, 400x600mm PNC 922747
- Trolley for grease collection kit PNC 922752
- Water inlet pressure reducer PNC 922773
- Extension for condensation tube, 37cm PNC 922776
- Non-stick universal pan, GN 1/1, H=20mm PNC 925000
- Non-stick universal pan, GN 1/1, H=40mm PNC 925001
- Non-stick universal pan, GN 1/1, H=60mm PNC 925002
- Double-face griddle, one side ribbed and one side smooth, GN 1/1 PNC 925003
- Aluminum grill, GN 1/1 PNC 925004
- Frying pan for 8 eggs, pancakes, hamburgers, GN 1/1 PNC 925005
- Flat baking tray with 2 edges, GN 1/1 PNC 925006
- Potato baker for 28 potatoes, GN 1/1 PNC 925008
- Compatibility kit for installation on previous base GN 2/1 PNC 930218

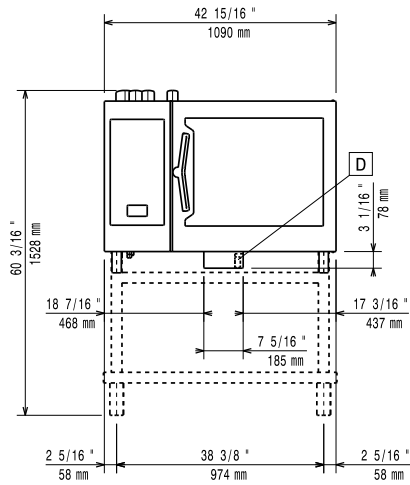
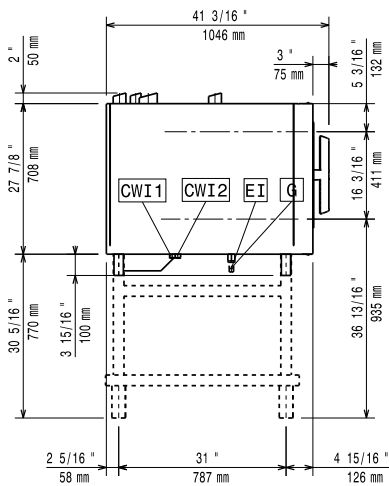
Front

Side

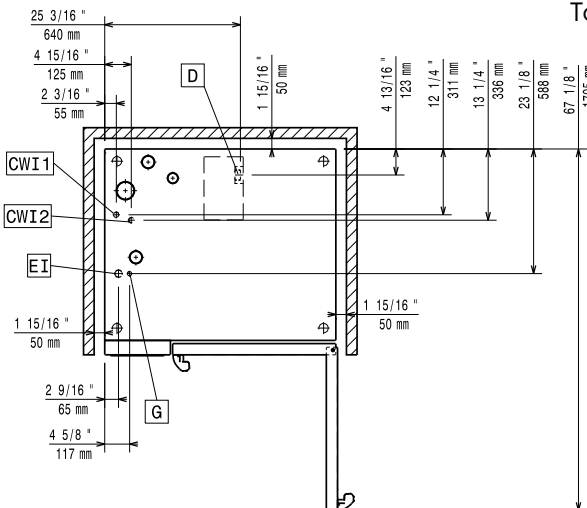
CWI1 = Cold Water inlet 1 (cleaning) EI = Electrical inlet (power)
 CWI2 = Cold Water Inlet 2 (steam generator) G = Gas connection
 D = Drain
 DO = Overflow drain pipe

Top

Electric

Supply voltage:

217861 (ECOG62B2H0) 220-240 V/1 ph/50 Hz

Electrical power, default:

1.5 kW

Default power corresponds to factory test conditions.

When supply voltage is declared as a range the test is performed at the average value. According to the country, the installed power may vary within the range.

Electrical power max.:

1.5 kW

Circuit breaker required

Gas

Gas Power:

32 kW

Standard gas delivery:

LPG, G31

ISO 7/1 gas connection diameter:

1/2" MNPT

LPG:

Total thermal load:

109088 BTU (32 kW)

Water:

Water inlet connections "CWI1-CWI2":

3/4"

Pressure, bar min/max:

1-6 bar

Drain "D":

50mm

Max inlet water supply temperature:

30 °C

Chlorides:

<17 ppm

Conductivity:

>50 µS/cm

Electrolux Professional recommends the use of treated water, based on testing of specific water conditions.

Please refer to user manual for detailed water quality information.

Installation:

Clearance:

Clearance: 5 cm rear and right hand sides.

Suggested clearance for service access:

50 cm left hand side.

Capacity:

Trays type:

6 - 2/1 Gastronorm

Max load capacity:

60 kg

Key Information:

Door hinges:

External dimensions, Width: 1090 mm

External dimensions, Depth: 971 mm

External dimensions, Height: 808 mm

Net weight: 173 kg

Shipping weight: 196 kg

Shipping volume: 1.28 m³