



**產品特點 FEATURES**

(不帶鼓風機 Without blower)

燃氣矮湯爐操作方便，火力集中，加熱速度快；能保持食物的原色原味，保證食物營養不受破壞；並可減少顧客等餐時間，燃燒噪音小。環保節能。安全可靠；內置高效能熄火安全裝置，確保工作環境安全可靠；

This Gas stock pot stove with convergent firepower and high heating rate assure to cook original color,taste and nutrition food with very short time and it also has advantages of low noise, sanitation,energy- saving and high safety, which is the ideal cooking equipment for chefs.Built- in flame failure device is also equipped for each burner to ensure safe operation

**產品特點 FEATURES**

(帶鼓風機 With blower)

3寸溝風爐頭，熱負荷:32kW；使用燃燒控制器,設置長明火種，脈衝電子點火，離子熄火保護；每個爐頭配一臺靜音風機(200V 50Hz 100W)，配備防水按鈕開關。

3"wind mixing burner,power:32kw;Using combustion controller, standby pilot ,electrical ignition,flame failure ion detective protection;each burner is equipped with a noiseless blower (200V 50Hz 100W), a button switch for waterproof.

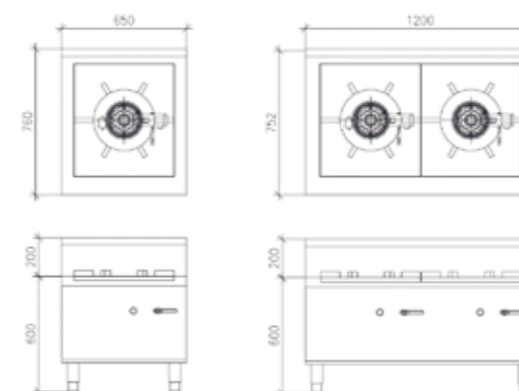
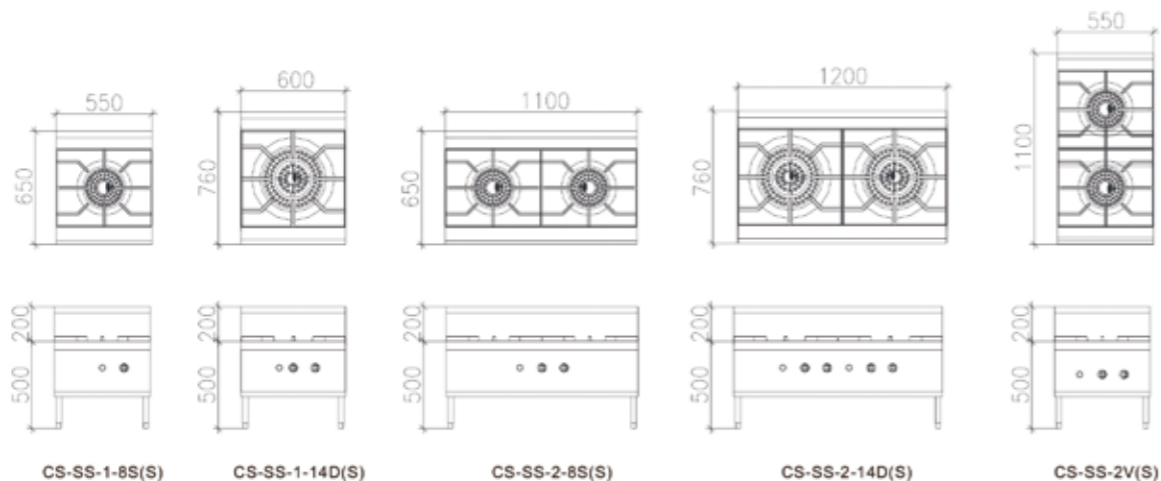

**規格參數表**

產品名稱 Product Name	型號 Model	規格 Dimension	熱負荷 Heat Load	進氣口 Gas Inlet	爐頭 Burner	備註 Remarks
燃氣單頭單圈矮湯爐	CS-SS-1-8S(S)	550x650x500+200	14kW	DN25	8寸強力爐頭	
燃氣單頭雙圈矮湯爐	CS-SS-1-14D(S)	600x760x500+200	24kW	DN25	14寸強力爐頭	
燃氣雙頭單圈矮湯爐	CS-SS-2-8S(S)	1100x650x500+200	14kWx2	DN25	8寸強力爐頭	
燃氣雙頭雙圈矮湯爐	CS-SS-2-14D(S)	1200x760x500+200	24kWx2	DN25	14寸強力爐頭	
燃氣雙頭單圈矮湯爐	CS-SS-2V(S)	550x1100x500+200	14kWx2	DN25	8寸強力爐頭	

燃氣額定壓力(Rated gas pressure)：天然氣為(NG)2000Pa, 人工煤氣為(TG)1000Pa,石油氣為(LPG)2800Pa

**規格參數表**

產品名稱 Product Name	型號 Model	規格 Dimension	熱負荷 Heat Load	進氣口 Gas Inlet	備註 Remarks
燃氣單頭矮湯爐(電磁安全制)	CS-PSE-1-F(E)	650x760x600+200	32kW	DN20	
燃氣雙頭矮湯爐(電磁安全制)	CS-PSE-2-F(E)	1200x760x600+200	32kWx2	DN20	

燃氣額定壓力(Rated gas pressure)：天然氣為(NG)2000Pa, 人工煤氣為(TG)1000Pa,石油氣為(LPG)2800Pa