

Winterhalter
U50/P50

winterhalter®



HIGH PERFORMANCE AT ITS CORE

HIGH QUALITY, EASY TO USE & PERFECT WASH

U50 Under counter dishwasher

The Winterhalter U50 undercounter dishwasher is built to meet the highest German quality standards and designed with simplicity and practicality in mind, for the needs of professionals in search of affordable and effective warewashing solutions. Users can trust its level of efficiency, reliability and cleaning performance. Backed by a comprehensive network of Winterhalter offices and partners in Asia, timely delivery, specialized service and parts availability are guaranteed. The U50 is optionally available with an integrated softener.

①

Excellent results and perfect hygiene

- elliptical wash fields with integrated washing and rinsing nozzles
- two wash fields ensure uniform coverage and dishwashing power from every angle
- deep drawn tank
- hygiene tank heater maintains constant tank temperature
- strainer filters coarse dirt out of the wash water
- smaller particles of dirt are held by the cylinder's fine filter
- integrated water softener as an option
- soft start: optimal protection of the wash items due to slow pressure build-up of circulating pump
- thermostop: reliable drying of wash items and optimal hygiene

②

Economical to run

- full coverage filtration system
- less water changes due to cleaner wash water
- low capacity wash tank for quicker start-up and lower bills
- double walled door with solid construction reduces noise and heat emission
- a well balanced system delivers the lowest rinse water consumption

③

Easy to use

- one button operation (display is colour coded)
- integrated temperature display for tank and boiler
- self-cleaning cycle
- self-explanatory buttons for easy operation

④

Easy to service

- integrated error management
- easy access to all relevant parts
- reduced down-time

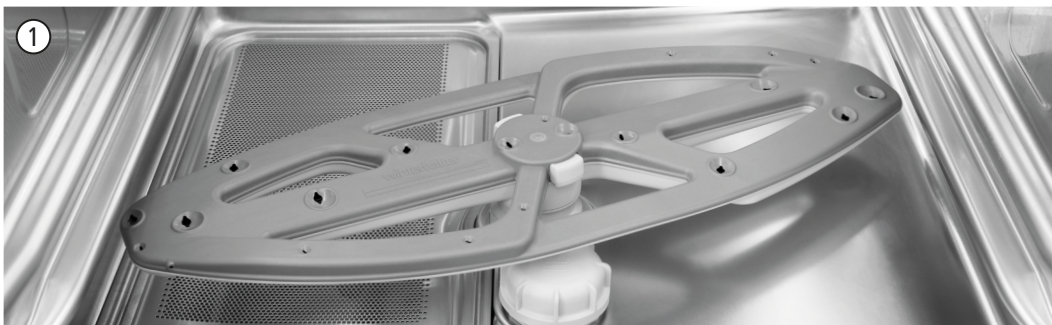

RESULTS

P50 Pass-through dishwasher

The Winterhalter P50 pass-through dishwasher is built to meet the highest German quality standards and designed with simplicity and practicality in mind, fitting the needs of professionals in search of affordable and effective warewashing solutions. Users can trust its level of efficiency, reliability and cleaning performance. Backed by a comprehensive network of Winterhalter offices and partners in Asia, timely delivery, specialized service and parts availability are guaranteed.

①

Excellent results and perfect hygiene

- rotating top and bottom wash system for optimum coverage
- triple filtration system ensures extended lifecycle of tank water
- deep drawn tank for optimal hygiene

②

Economical to run

- short wash cycle
- reduced heating time
- low total connected load at 3-ph 20 Amp
- low fresh water consumption
- optional integrated water heat exchanger with additional 1.7 kW heating power helps to save energy costs

③

Easy to use

- clear colour-coded digital display
- two wash programmes
- digital tank and boiler temperature display

④

Easy to service

- integrated error management
- easy access to all relevant parts
- reduced down-time



U50 Under counter dishwasher

Number of programmes		2
Theoretical capacity ¹ standard / HighTemp	[racks/h]	30 / 20
Rack dimensions	[mm]	500 x 500
Water consumption		
Tank capacity	[l]	15.3
Rinse water consumption ² per cycle standard / HighTemp	[l]	2.4 / 3.4
Temperatures		
Tank temperature standard / HighTemp	[°C]	62 / 66
Rinse temperature	[°C]	85
Max. water inlet temperature	[°C]	60
Other information		
Circulating pump (P1)	[kW]	0.5
Noise emission	[dB(A)]	max. 59
Packaging dimensions	(W x D x H) [mm]	720 x 712 x 1020
Splash guard		IP X3
Weight, net / gross	[kg]	66 / 76

Electrical specifications

Supply	Fuse	Tank	Boiler	Total connected load
360 V - 415 V / 3N ~ 50/60 Hz	16 A	2.0 kW	5.3 kW	7.8 kW
220 V - 240 V / 1N ~ 50/60 Hz	16 A	2.0 kW	2.6 kW	3.1 kW
	20 A	2.0 kW	3.6 kW	3.1 kW
220 V - 240 V / 3 ~ 50/60 Hz	25 A	2.0 kW	5.3 kW	7.8 kW

P50 Pass-through dishwasher

Number of programmes		2
Theoretical capacity ³	[racks/h]	60 / 20
Rack dimensions	[mm]	500 x 500
Water consumption		
Tank capacity	[l]	28
Rinse water consumption ² per cycle standard / HighTemp	[l]	2.4 / 3.8
Temperatures		
Tank temperature standard / HighTemp	[°C]	62 / 66
Rinse temperature	[°C]	85
Max. water inlet temperature	[°C]	60
Tank heating	[kW]	2.5
Boiler heating	[kW]	9.0
Other information		
Circulating pump (P1)	[kW]	0.6
Noise emission	[dB(A)]	max. 63
Packaging dimensions	(W x D x H) [mm]	770 x 880 x 1605
Splash guard		IP X3
Weight, net / gross	[kg]	98 / 123

Electrical specifications

Supply	Fuse	Total connected load
400 V - 240 V / 3N ~ 50-60 Hz	16 A	9.3 kW
	20 A	11.8 kW
	25 A	9.3 kW
230 V - 240 V / 3N ~ 50-60 Hz	32 A	11.8 kW

¹ By adjusting parameters the theoretical capacity can be increased to 60 racks / h (1-minute-programme).

² Non-binding information. The actual need for rinse water can vary depending on the on-site conditions.

³ Depending on the local conditions (water inlet temperature / electrical supply) the indicated data can decrease.

DIMENSIONS

U50 Under counter dishwasher

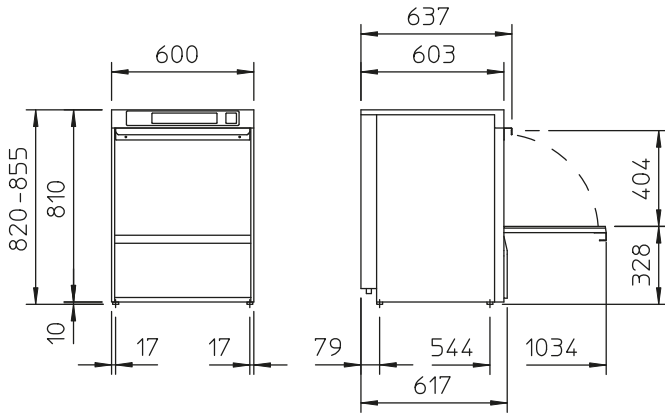

P50 Pass-through dishwasher

