



### PRODUCT FEATURES

- Deck forced refrigeration
- Sliding doors front and rear
- Double glazed
- Two adjustable shelves
- Ticket strips on shelves and deck
- Undershelf and canopy LED lights
- Integral condensor
- Self evaporating
- Solid glass front - optional

### CABINET DIMENSIONS & SPECIFICATIONS

Refrigerated 4<sup>0</sup> factory set point

Model	Cabinet			Shelving no.	Display m2	Total food units	Refrigerant	Operating Current	Connection	Voltage
	Length mm	Depth mm	Height mm							
STGRF6	600	650	925	2 + base		100 x 100 mm	134a	4.7 Amp	10amp 3 pin plug	50/60 Hertz

\* prior to installation see, installation guidelines, ventillation requirements and drainage options documents

### ELECTRICAL POWER

Electrical power cord 2200mm  
 3 pin 10 amp 1 phase socket required.  
 Maximum ambient operating temperature climate class N max 32°C

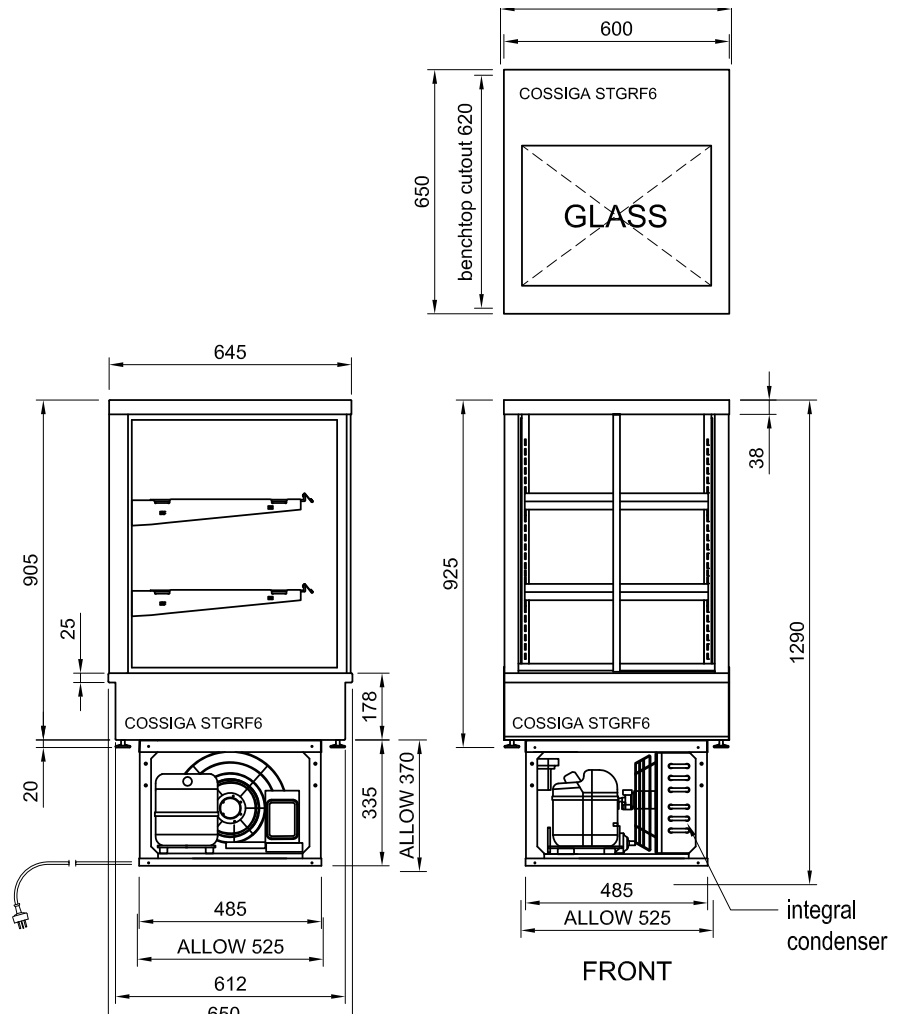



### PRODUCT FEATURES

- Deck forced refrigeration
- Sliding doors front and rear
- Double glazed
- Two adjustable shelves
- Ticket strips on shelves and deck
- Undershelf and canopy LED lights
- Integral condensor
- Self evaporating
- Solid glass front - optional

### CABINET DIMENSIONS & SPECIFICATIONS

Refrigerated 4<sup>0</sup> factory set point

Model	Cabinet			Shelving no.	Display m2	Total food units	Refrigerant	Operating Current	Connection	Voltage
	Length mm	Depth mm	Height mm							
STGRF9	900	650	925	2 + base		100 x 100 mm	134a	5.0 Amp	10amp 3 pin plug	50/60 Hertz

\* prior to installation see, installation guidelines, ventillation requirements and drainage options documents

### ELECTRICAL POWER

Electrical power cord 2200mm  
 3 pin 10 amp 1 phase socket required.  
 Maximum ambient operating temperature climate class N max 32°C

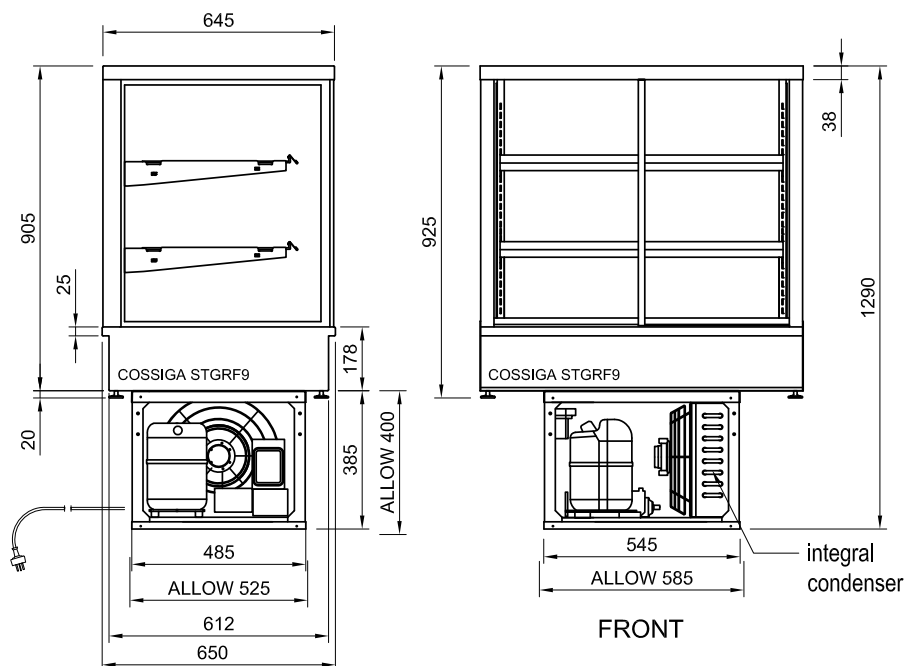
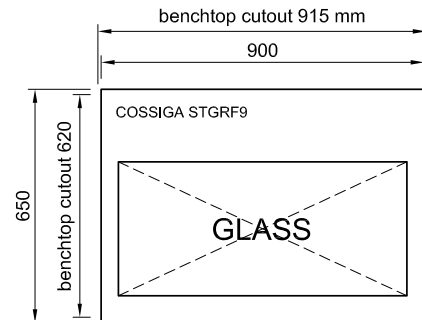



### PRODUCT FEATURES

- Deck forced refrigeration
- Sliding doors front and rear
- Double glazed
- Two adjustable shelves
- Ticket strips on shelves and deck
- Undershelf and canopy LED lights
- Integral condensor
- Self evaporating
- Solid glass front - optional

### CABINET DIMENSIONS & SPECIFICATIONS

Refrigerated 4<sup>0</sup> factory set point

Model	Cabinet			Shelving no.	Display m2	Total food units	Refrigerant	Operating Current	Connection	Voltage
	Length mm	Depth mm	Height mm							
STGRF12	1200	650	925	2 + base		100 x 100 mm	134a	6.8 Amp	10amp 3 pin plug	50/60 Hertz
						121				240V

\* prior to installation see, installation guidelines, ventillation requirements and drainage options documents

### ELECTRICAL POWER

Electrical power cord 2200mm  
 3 pin 10 amp 1 phase socket required.  
 Maximum ambient operating temperature climate class N max 32°C

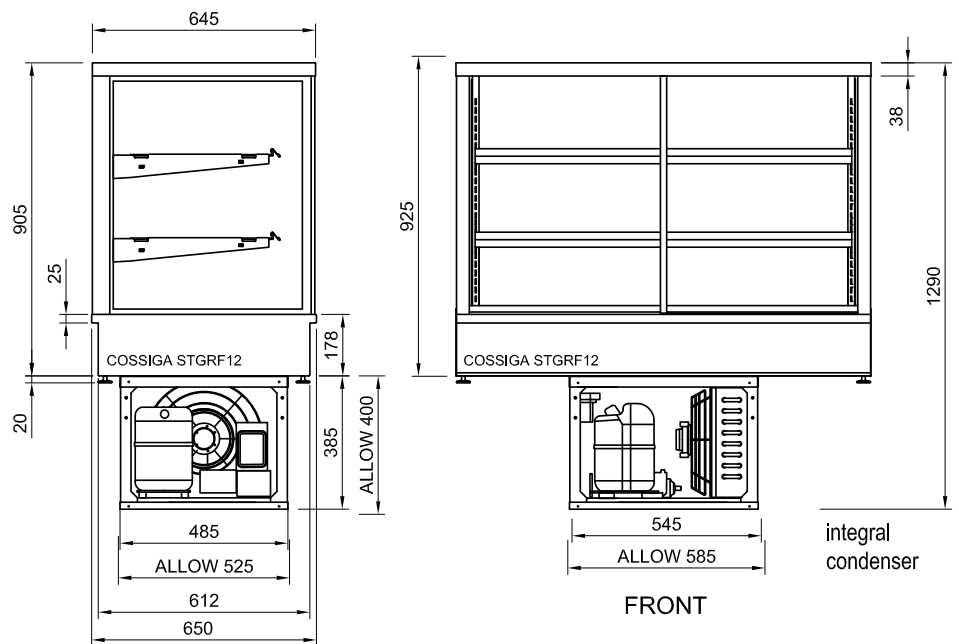
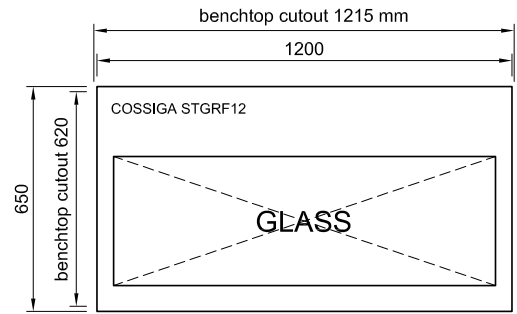



### PRODUCT FEATURES

- Deck forced refrigeration
- Sliding doors front and rear
- Double glazed
- Two adjustable shelves
- Ticket strips on shelves and deck
- Undershelf and canopy LED lights
- Integral condensor
- Self evaporating
- Solid glass front - optional

### CABINET DIMENSIONS & SPECIFICATIONS

Refrigerated 4<sup>0</sup> factory set point

Model	Cabinet			Shelving no.	Display m2	Total food units	Refrigerant	Operating Current	Connection	Voltage
	Length mm	Depth mm	Height mm							
STGRF15	1500	650	925	2 + base		100 x 100 mm	134a	7.0 Amp	10amp 3 pin plug	50/60 Hertz
						154				240V

\* prior to installation see, installation guidelines, ventillation requirements and drainage options documents

### ELECTRICAL POWER

Electrical power cord 2200mm  
 3 pin 10 amp 1 phase socket required.  
 Maximum ambient operating temperature climate class N max 32°C

